

Table of Contents

General Information

Welcome	3
Academic Calendar	4
Policies	9
Role of Branch Colleges	9
Mission	10
Educational Programs	10
Operating Agreement	11
Accreditation	11
Student Outcomes Assessment	11
History	11
Location	12
Faculty	12
Facilities	12
Housing	12
Bookstore	13
Library	13
Adult Learning Center	13
Community Education	14
Customized Training	14
Small Business Development Center	14
Contract Training	14
College Cornerstone Program	14

Admissions

General	14
Beginning Freshmen	15
Dual Credit	15
Concurrent Enrollment	15
Transferring Students	16
Readmitted Students	18
Alternative Credit Programs	19

Non-degree Credit Programs	19
International Students	21
Undergraduate Admissions	22

Student Services Information

Records	25
Residency	28
Student Identification Cards	29
Enrollment	30
General Academic Regulations	31
Financial Aid	37
Publications	40
Student Organizations	40

Associate Degrees and Academic Certificates

List of programs	42
Associate of Arts in Early Childhood	
Multicultural Education	48
Associate of Arts in Liberal Arts	50
Associate of Arts in Pre-Business Administration	54
Associate of Arts in Pre-Professional Elementary Education	56
Associate of Arts in Studio Art	58
Associate of Science in Environmental Science	59
Associate of Science in Pre-Engineering	61
Associate of Science in Science	63
Associate of Applied Science in Accounting	65
Associate of Applied Science in Applied Technologies	66
Associate of Applied Science in Business	68
Associate of Applied Science in Computer Science	70
Associate of Applied Science in Digital Media Arts	73

Table of Contents

Associate of Applied Science in General Studies	74	Workforce Development	
Associate of Applied Science in Network Administration	75	Employability Certificates	92
Associate of Applied Science in Office Communications and Technology	78	Cooperative Education	95
Associate of Applied Science in Technical Support	79	Internships	95
Associate of Applied Science in Web Technologies	80	Career/Technical Pathways	96
Certificate in Accounting	82	Specialized Training for Workforce Support	96
Certificate in Business	83	Paralegal Training	96
Certificate in Computer Science	84	Project Management Training	97
Certificate in Digital Media Arts	85	Course Descriptions	98
Certificate in Electro Mechanical Technology	85	Bachelor and Graduate Program	145
Certificate in Early Childhood Multicultural Education	86	Governing Bodies, Staff and Core Faculty	147
Certificate in Materials Science Technology	86	Index	150
Certificate in Network Administration	87		
Certificate in Office Communications and Technology	88		
Certificate in Pre-Professional Elementary Education	89		
Certificate in Studio Art	90		
Certificate in Technical Support	90		
Certificate in Web Technologies	91		

Welcome UNM-LA Students and Community

On behalf of the staff and faculty, it is a pleasure to welcome our students and the community to UNM Los Alamos (UNM-LA) for the fall 2009 Semester. UNM-LA has been serving the northern New Mexico Community since 1980. Registration is currently underway and fall semester classes begin August 24. The Fall Schedule for both credit and Community Education courses is available on-line at www.la.unm.edu, on campus, and at many locations throughout Los Alamos, Rio Arriba and Sandoval counties.

As a branch campus of the largest university in the state, we are able to offer our students many benefits including a tuition rate that is one-fourth the cost of tuition at the Albuquerque campus for lower division courses and lower than other associate degree granting colleges in northern New Mexico. We also offer small class sizes for effective teaching-learning; and affordable student housing close to campus.

Our qualified and dedicated faculty place teaching as their top priority. Because of our proximity to Los Alamos National Laboratory, we are able to attract exceptionally talented individuals to teach in many disciplines at our campus. Our professional staff place student service, support and satisfaction as their top priorities. We believe the factors that contribute to the quality of your learning experience extend beyond the classroom.

UNM-LA offers coursework and programs geared to those seeking an associate degree or certificate in many exciting fields of study. New and planned degree programs and concentrations at UNM-Los Alamos include: marketing, finance, web technologies, and public safety. Through coordination with the Bachelors and Graduate Programs division of the University of New Mexico, students can complete a bachelor's or a master's degree in selected disciplines at UNM-LA or take courses applicable to other UNM degree programs.

As a community resource and asset, throughout the year we host lectures, art shows, concerts and other special events for the enjoyment of our students and the communities we serve. A number of special events are planned this academic year and they will be announced on our website www.la.unm.edu. The UNM LA staff and faculty are committed to providing the educational experience and services essential to your success at here and beyond. We understand the role and value of high quality education and training to the residents of northern New Mexico and we are ready continue delivering the education and training expected by the diverse populations and employers throughout northern New Mexico.

We welcome you to our campus community and wish you great success in the coming academic year. We continually strive to make UNM-LA the **best place** for you to realize your educational goals and enhance your skills. Working together, we will continue to make UNM-LA a vibrant and exciting place for all of us to learn, advance, and contribute to the vitality of our local communities and economy. I look forward to seeing you on campus!

Cedric D. Page, Ph.D.

Cedric D. Page, Ph.D.

Executive Director

Academic Calendar

Fall Semester	2009	2010
Instruction begins	August 24, Monday	August 23, Monday
Registration ends - last day to add courses or change sections - 16-week term - First 8-week term - Second 8-week term	September 4, Friday August 28, Friday October 23, Friday	September 3, Friday August 27, Friday October 22, Friday
Labor Day, holiday	September 7, Monday	September 6, Monday
Last day to drop a course without a grade - 16-week term (end of third week) - First 8-week term (end of second week of course) - Second 8-week term (end of second week of course)	September 11, Friday September 4, Friday October 30, Friday	September 17, Friday September 3, Friday October 29, Friday
- Mid-semester (eighth week)	October 17, Saturday	October 16, Saturday
Last day to change grading options - 16-week term (end of fourth week) - First 8-week term (end of second week of course) - Second 8-week term (end of second week of course)	September 18, Friday September 4, Friday October 30, Friday	September 17, Friday September 3, Friday October 29, Friday
Columbus Day (No lower division classes) Campus open	October 12, Monday	October 11, Monday
Fall Break (upper division and graduate only) Campus open	October 15-16, Thursday, Friday	October 14-15 Thursday, Friday
Veterans Day (no lower division classes) Campus open	November 11, Wednesday	November 11, Thursday
Last day to withdraw without approval of college dean - 16-week term (end of twelfth week) - First 8-week term (end of sixth week of course) - Second 8-week term (end of sixth week of course)	November 13, Friday October 2, Friday December 4, Friday	November 12, Friday October 1, Friday December 3, Friday

Academic Calendar

Fall Semester	2009	2010
Thanksgiving, holiday	November 26-29, Thursday-Sunday	November 25-28, Thursday-Sunday
Last day to withdraw from a course with approval of Student Services - 16-week term - First 8-week term - Second 8-week term	December 11, Friday October 16, Friday December 11, Friday	December 10, Friday October 15, Friday December 10, Friday
Last day of instruction - 16-week term - First 8-week term - Second 8-week term	December 12, Saturday October 17, Saturday December 12, Saturday	December 11, Saturday October 16, Saturday December 11, Saturday
Final examination period (Monday - Saturday)	December 14-19, Monday-Saturday	December 13-18, Monday-Saturday
Last day to report removal of incomplete grade - 16-week term	December 18, Friday	December 17, Friday
Semester ends - 16-week term - First 8-week term - Second 8-week term	December 19, Saturday October 17, Saturday December 19, Saturday	December 18, Saturday October 16, Saturday December 18, Saturday
Tentative start date Fall 2011 - August 22, 2011		

Academic Calendar

Spring Semester	2010	2011
Undergraduate application and credentials deadline	November 15, 2009 Sunday	November 15, 2010 Monday
Martin Luther King, Jr. Day, holiday	January 18, Monday	January 17, Monday
Instruction begins - 16-week term - First 8-week term - Second 8-week term	January 19, Tuesday January 19, Tuesday March 15, Monday	January 18, Tuesday January 18, Tuesday March 16, Monday
Registration ends - last day to add courses or change sections - 16-week term - First 8-week term - Second 8-week term	January 29, Friday January 22, Friday March 26, Friday	January 28, Friday January 21, Friday March 25, Friday
Last day to drop a course without a grade - 16-week term (end of third week) - First 8-wk term (end of 2nd week of course) - Second 8-wk term (end of 2nd week of course)	February 5, Friday January 29, Friday April 2, Friday	February 4, Friday January 28, Friday April 1, Friday
Mid-semester (eighth week)	March 13, Saturday	March 12, Saturday
Last day to change grading options - 16-week term (end of third week) - First 8-wk term (end of 2nd week of course) - Second 8-wk term (end of 2nd week of course)	February 12, Friday January 29, Friday April 2, Friday	February 11, Friday January 28, Friday April 1, Friday
Spring Recess (upper division and graduate only) Campus open	March 14-21, Sunday-Sunday	March 13-20, Sunday-Sunday

Academic Calendar

Spring Semester	2010	2011
Spring Recess (lower division only) Campus Open	March 28-April 3	March 27-April 2
Last day to withdraw without approval of Student Services -- 16-week term - First 8-wk term (end of 2nd week of course) - Second 8-wk term (end of 2nd week of course)	April 16, Friday February 26, Friday April 30, Friday	April 15, Friday February 25, Friday April 29, Friday
Last day to withdraw from a course with approval of Student Services - 16-week term - First 8-week term - Second 8-week term	May 7, Friday March 12, Friday May 7, Friday	May 6, Friday March 11, Friday May 6, Friday
Last day of instruction - 16-week term - First 8-week term - Second 8-week term	May 8, Saturday March 13, Saturday May 8, Saturday	May 7, Saturday March 12, Saturday May 7, Saturday
Final examination period	May 10-15, Monday-Saturday	May 9-14, Monday-Saturday
Last day to report removal of incomplete grade - 16-week term - First 8-week term - Second 8-week term	May 14, Friday	May 13, Friday
Semester ends - 16-week term - First 8-week term - Second 8-week term	May 15, Saturday March 13, Saturday May 15, Saturday	May 14, Saturday March 12, Saturday May 14, Saturday

Academic Calendar

Summer Semester	2010
Undergraduate application and credentials deadline	May 1, Saturday
Instruction begins - 8-week term - First 4-week term - Second 4-week term	June 7, Monday June 7, Monday July 6, Tuesday
Registration ends - last day to add courses or change sections - 8-week term - First 4-week term - Second 4-week term	June 11, Friday June 8, Tuesday July 7, Wednesday
Last day to change grading options - 8-week term - First 4-week term - Second 4-week term	June 18, Friday June 11, Friday July 9, Friday
Last day to drop a course without a grade - 8-week term - First 4-week term - Second 4-week term	June 25, Friday June 16, Wednesday July 14, Wednesday
Last day to withdraw without approval of Student Services - 8-week term - First 4-week term - Second 4-week term	July 16, Friday June 25, Friday July 23, Friday
Independence Day, holiday - Campus Closed	July 4, Sunday July 5, Monday
Session ends - 8-week term - First 4-week term - Second 4-week term	July 31, Saturday July 3, Saturday July 31, Saturday

Policies

Applicability

These policies apply to outreach, admission, extracurricular activities, housing, facilities, access to course offerings, counseling and testing, financial assistance and employment.

Anti-Harassment

It is the policy of the institution to prevent and eliminate forms of unlawful harassment in employment and educational settings. The University prohibits harassment of employees by supervisors or coworkers and harassment of students on the basis of race, color, religion, national origin, physical or mental disability, age, sex, sexual preference, ancestry, medical condition or other protected status. The University makes special efforts to eliminate both overt and subtle forms of sexual harassment.

Equal Education Policy

The University of New Mexico is committed to providing equal educational opportunity and forbids unlawful discrimination and/or harassment on the basis of race, color, religion, national origin, physical or mental disability, age, sex, sexual preference, ancestry, or medical condition. Equal educational opportunities includes: admission, recruitment, academic endeavors, extracurricular programs and activities, housing, health and insurance services and athletics. In keeping with this policy of equal educational opportunity, the University is committed to creating and maintaining an atmosphere free from all forms of harassment.

ADA Compliance and Reasonable Accommodation

The University of New Mexico-Los Alamos is committed to the recognition and the proactive pursuit of compliance with the Americans with Disabilities Act of 1990 (ADA). The University makes reasonable accommodation for religious observances, national origin practices of a student and to the known physical or mental limitations of a qualified student, unless such accommodations have the end result of fundamentally altering a program or service or placing an undue hardship on the operation of the University.

Qualified students with disabilities should contact Student Services for information regarding accommodations in the academic and/or employment setting. If you have a special need and require an auxiliary aide and/or service, please contact Student Services at 505-661-4692.

Non-Discrimination

If you believe you have been discriminated against and/or harassed on the basis of your race, religion, color, national origin, physical or mental disability, age, sex, sexual preference, ancestry, or medical condition, you should contact the Director of Student Services who serves as the Coordinator for the Americans with Disabilities Act of 1990 (prohibiting discrimination on the basis of disability) and Title IX of the Education Amendments Act of 1972 (prohibiting discrimination on the basis of sex in federally funded programs). The Director can be reached at 505-661-4692. You can also access information on the OEO web site at <http://oeodm.od.nih.gov/>.

UNM-Los Alamos General Information

Role and Function of UNM Branch Colleges

The University of New Mexico has established branch colleges to serve the citizens of New Mexico more fully and to provide the highest quality education throughout the state for students in different locations pursuing postsecondary education. Branch colleges respond specifically to the unique needs and multicultural backgrounds of the citizens in the respective communities they serve by offering transfer programs that prepare students for upper-division entry into colleges and universities. In addition the branches offer associate degree and certificate programs. Branch colleges use resources in the community as well as making educational resources available. Therefore, they also function as an integral part of the community.

The five-member elected UNM-Los Alamos Advisory Board serves as an advisory body to the College and to the University of New Mexico Board of Regents. It approves the annual budget and can call for elections. UNM-Los Alamos continues to benefit from a strong, supportive, and dedicated Advisory Board which is well informed, responsible, and committed to the College and its future. The branch colleges of the University of New Mexico are considered fully integrated component colleges. They are committed to serving the needs of their respective communities as comprehensive community colleges offering a variety of preparatory academic, career, and community service programs. The branch colleges pledge themselves to protect the quality and integrity of all academic curricula. UNM Albuquerque campus pledges its resources, whenever appropriate and practical, to

the fulfillment of the varied missions of the branches.

The Provost/Vice President for Academic Affairs at the University of New Mexico has responsibility for the operation of the branch colleges. From a clear understanding of its role and function, UNM-Los Alamos has developed the following mission statement.

Mission of UNM-Los Alamos

The mission of the University of New Mexico-Los Alamos is to provide high quality instructional programs and support services to the residents of the communities it serves. To fulfill its mission, UNM-Los Alamos has established the following goals:

1. To offer diversified, high-quality educational programs:
 - Academic Courses, Degrees, and Transfer Curricula
 - Technical and Occupational Programs
 - Developmental and Basic Skills Programs
 - Community Education
 - Adult Basic Education
 - Specialized Training
 - Extended Web, ITV, and Off-Site Instruction
2. To provide high-quality support services that promote student access and success
3. To maintain a highly qualified and diversified faculty and staff
4. To serve as a community resource
5. To seek and establish cooperative partnerships
6. To ensure access to state-of-the-art technologies

Educational Programs

The University of New Mexico-Los Alamos offers a range of educational programs as defined in the Mission Statement and institutional goals. These programs constitute the heart of the institution.

Academic transfer programs for credit provide the first two years of high quality university education. UNM-Los Alamos is authorized to offer any freshman or sophomore course that appears in the UNM Albuquerque campus catalog for which an appropriate instructor and facilities can be obtained. In addition, UNM-Los Alamos may design courses that respond to the needs of its students. Most of these courses carry full UNM residence credit as though they were taken in Albuquerque. Thus students enrolled in academic transfer courses may complete most of and, in many cases, all of the first two years of a baccalaureate degree at UNM-Los Alamos before continuing their studies at UNM or other four-year institutions.

Associate of Arts and Associate of Science degrees are offered in the following fields: Early Childhood Multicultural Education (Bernalillo Site Only), Environmental Science, Liberal Arts, Pre-Business Administration, Pre-Professional Elementary Education (Bernalillo Site Only), Pre-Engineering, Science, Southwest Studies and Studio Art. Certificates are available in Early Childhood Multicultural Education (Bernalillo Site Only), Southwest Studies, and Studio Art. These programs are considered to be transfer programs because all or most of the courses required transfer to other four-year colleges and universities.

Occupational and technical programs are offered for academic credit. Associate of Applied Science Degrees in Business, Office Communications and Technology, Computer Science, Digital Media Arts, Electro-Mechanical Technology, Accounting, Network Administration, Technical Support, and Web Technologies are available. Certificates are offered in Office Communications and Technology, Business, Computer Science, Digital Media Arts, Electro-Mechanical Technology, Accounting, Materials Science Technology, Network Administration, Technical Support, and Web Technologies. A statement of completion is available for the Child Development Associate Credential Preparation Program (CDA).

UNM-Los Alamos also offers Bachelor's Degrees on this campus in Computer Science, University Studies, Chemical-Nuclear Engineering, Electrical and Computer Engineering and Mechanical Engineering. Masters program courses are offered in Computer Science, Public Administration, Educational Leadership and Engineering.

An Associate Degree in General Studies provides students the opportunity to develop programs of study not available through other UNM-Los Alamos programs. The courses selected may reflect either specialized or broad patterns of educational experience.

Introductory Studies credit courses are offered in math, English, reading comprehension, and academics. The Introductory Studies courses are components of the College Cornerstone program, which is designed to help students strengthen their areas of academic competencies, as well as ensure successful transition into college.

Adult Basic Education and English as a Second Language courses are also offered for students who are not adequately prepared for college-level work.

The Tutorial Center provides tutorial services for 100-and 200-level classes to all students on campus and services for students with special needs.

UNM-LA offers nine Employability Certificates that provide students the option to gain expertise in a focused, marketable skill set. These skill sets represent areas of employment where the Federal Department of Labor and New Mexico State Labor statistics project growing needs over the next four years. Note: Qualified students may receive financial support from the (New Mexico) Northern Area Workforce Board for earning the certificates. To learn more about this program and whether or not you qualify for financial support, visit Workforce Board website at www.dws.state.nm.us or visit the Career/OneStop Center in the Student Services building of UNM-LA.

Operating Agreement and Funding

UNM-Los Alamos was established under the provisions of the Branch College Act, New Mexico Statutes of 1978, implemented in an operating agreement between the Los Alamos School Board and the Regents of the University of New Mexico. The New Mexico Department of Higher Education, a thirteen-member board appointed by the Governor, is responsible for oversight of higher education in New Mexico. The UNM-Los Alamos Advisory Board serves as the Advisory Board to the UNM Board of Regents. This Advisory Board approves an annual budget for UNM-Los Alamos and calls elections for local tax levies and capital outlay general obligation bonds for UNM-Los Alamos. The University of New Mexico retains administrative and academic oversight of UNM-Los Alamos, and the Executive Director of UNM-Los Alamos reports to the Vice President for Rio Rancho and Branch Academic Affairs and the Provost/Vice President for Academic Affairs. Funding for UNM-Los Alamos comes directly from state appropriations and tax levies, from special grants, and from tuition and fees paid by students.

Accreditation

As a Branch College of the University of New Mexico, UNM-Los Alamos is fully accredited by The Higher Learning Commission of the North Central Association of Colleges and Schools.

Student Outcomes Assessment

Student Outcomes Assessment is an essential measure of the institution's effectiveness in achieving its goals as outlined in the UNM-Los Alamos Mission Statement. It is an ongoing process intended to measure student academic achievement and adjust and adopt courses and programs as needed. Faculty have the primary ownership and responsibility for the development, implementation, and monitoring as part of the College Assessment

Review Committee (CARC). Specific competencies at the course/program level and the assessment tools to measure identified competencies are continuously being developed and continuously being implemented. See the current report at <http://www.la.unm.edu/administration/assessment.html>

History of UNM-Los Alamos

The University of New Mexico began its presence in Los Alamos in 1956 with the establishment of the UNM Los Alamos Center for Graduate Studies. The Graduate Center has been in continuous operation since that time. It has a distinguished history of offering graduate degrees in scientific, engineering, management, and health-related fields. The first significant UNM undergraduate offering in Los Alamos began with the establishment of the University of New Mexico Residence Center in Los Alamos in the fall of 1970. In 1973, the University of New Mexico Northern New Mexico Branch College came into existence, with Los Alamos as one of its campuses. In 1977, as a result of Legislative action, the UNM Northern Branch College was absorbed into Northern New Mexico Community College (NNMCC).

In 1980, after a local referendum and Board of Educational Finance and legislative approval, the Los Alamos Branch Community College Campus of the University of New Mexico was founded. It began operations on July 1, 1980, in the Little Valley School on Orange Street. The new Director assumed his duties at that time, and several key NNMCC employees were transferred to the UNM-Los Alamos Branch College, which subsequently assumed the informal title of UNM-Los Alamos.

In October 1980, the campus moved from the Little Valley School to its present site. In January 1981, the staff of UNM-Los Alamos assumed, under a contractual arrangement, the daily operations of the UNM-Los Alamos Center for Graduate Studies from the Training Office of the Los Alamos National Laboratory. The Director of the Graduate Center moved his office to UNM-Los Alamos. During 1982-1983, the facilities were remodeled and expanded and the new UNM-Los Alamos campus was dedicated by then Governor of New Mexico, Toney Anaya, on January 6, 1984. The campus facilities were further expanded in 1987 to include a fifth classroom building.

During 1988-89, an institutional self-study was conducted and an accreditation visit took place in May 1989 as part of the University of New Mexico decennial accreditation review. In 1988, the Los Alamos School Board approved additional space in the Mesa Complex for use by UNM-Los Alamos. In 1996, an extension housing the Learning Center, the Tutorial Center, and the Adult Basic Education Program was added to the administration building. Additional classroom, laboratory and office space was obtained in 1997 by negotiation with the Los Alamos Public Schools. In 2000 the expanded and renovated Student Center building was opened. It includes a Student Center with a food service area, classrooms, media room and lecture hall. In addition the Student Services support areas including admissions and registration, advisement, and financial aid are located in the lower level of this building.

Location

Los Alamos, home of the University of New Mexico-Los Alamos campus, is a community of approximately 18,000. The town is located on the pinon, juniper, and ponderosa-covered red mesas of the Pajarito Plateau at an elevation of 7,300 feet. The Jemez Mountains provide a backdrop for the community that looks east across the Rio Grande Valley to the majestic Sangre de Cristo Mountains.

The setting is ideal for the outdoor enthusiast. There are nearby locations for downhill and cross-country skiing and ice skating in the winter. Summer activities include hiking, picnicking, horseback riding, backpacking, and camping, together with fishing and river rafting. Three renowned races are held in Los Alamos each year: the High Altitude Mini-Marathon, the Tour de Los Alamos Bicycle Race, and the Triathlon. In April 1988, the Larry R. Walkup Aquatic Center opened its doors to the citizens of Los Alamos and surrounding area. This facility is open to the public and houses an Olympic-sized swimming pool.

There are year-round musical and theatrical events in Los Alamos and numerous other cultural attractions to choose from in Santa Fe, 30 miles away, and in Albuquerque, a 90-mile drive from Los Alamos. There are also year-round events at the nearby pueblos of San Ildefonso, Santa Clara, San Juan, Pojoaque, Tesuque, Nambe, and Jemez. Located within 15 miles of Los Alamos is the world famous Bandelier National Monument. The park, home of Native American cliff dwellings as well as many other ancient treasures, is open year-round. Students at UNM-Los Alamos are fortunate to be able to draw on the rich tri-cultural heritage of the area and to explore all the area has to offer in terms of history, geology, and archaeology. In addition, UNM-Los Alamos students can take advantage of the outstanding collections of Mesa Public Library and the J. Robert Oppenheimer Study Center at Los Alamos National Laboratory, within two miles of the UNM-Los Alamos campus.

UNM-Los Alamos Faculty

The faculty of UNM-Los Alamos is predominately part-time. Many of the faculty enjoy international reputations in their fields and all are extremely well qualified. Most UNM-Los Alamos faculty are subject to UNM approval through the various departments at the UNM Albuquerque campus. About one-third of the UNM-Los Alamos faculty consists of a core of continuing faculty. Core Faculty members, in addition to teaching, hold regular office hours, provide academic advisement, and participate in a variety of committee work and special projects. Invited Faculty are encouraged, but not required, to participate in advisement, hold office hours, and attend various faculty development workshops throughout the academic year. Curriculum Coordinators for Developmental and General Studies, Fine Arts, Communications, Math, Science, Applied Technologies, Computer Science, Information Technology, and Business are responsible for the coordination of faculty and instructional issues within each curriculum area. Two Division Heads, one Math, Science, Engineering, Communications and Fine Arts and one for Business, Computer Science,

Information Technology and General Studies advise the administration on curriculum and academic personnel matters and, with the Dean of Instruction, monitor the quality of teaching through classroom visits. Other means of class evaluation may include a mid-semester evaluation survey, a classroom assessment technique of the teacher's choosing, and a UNM computerized student evaluation survey at the end of the semester.

UNM-Los Alamos Facilities

The facilities at UNM-Los Alamos encompass computer, general science and electronics laboratories, a photography darkroom and art studios, together with general classrooms, woodworking area and a machine shop/welding area. The new Student Services Building, which opened in the summer of 2000, includes the Career Resources Center, UNM-LA Bookstore, Admissions, Registration, Financial Aid, Academic Advisement, Student Government, a lecture hall and general classrooms. The Administration Building (Building 1) includes general offices, the Library, and Tutorial Center. Parking facilities are available in the campus parking lot east of campus. Access to these facilities is available directly from in the High School's "Topper" lot located next to Sullivan Field and also in a shared parking lot west of the campus. Handicapped parking and access are available at UNM-Los Alamos. Handicapped parking is located on the cul-de-sac north of the campus at the end of 40th Street and in front of Building 1. Most of the facilities at UNM-Los Alamos and at the Los Alamos High School are handicapped accessible.

Student Housing

The University of New Mexico-Los Alamos Student Housing consists of 64 efficiency apartments. Student Housing provides an excellent and affordable alternative for students. In addition, living in student housing allows students the opportunity to become independent, responsible and familiar with different lifestyles.

All of the units include a primary living/sleeping area, kitchenette, three-quarter and/or full bath, and a walk-in closet. Each unit is furnished with a sofa, table, chairs, desk, dresser and bed. Electricity, gas, water, garbage service and basic cable television are included at no extra cost. All apartments have individually controlled thermostats. Pets and smoking are not permitted. Student Housing is located on 9th street, a three-minute drive east of UNM-Los Alamos. The apartments are centrally located to The Family YMCA, shopping and dining areas, the Bradbury Science Museum, and the central business district. To be eligible, students must be enrolled in a minimum of three credit hours in a degree-seeking program or in a student-related program with Los Alamos National Laboratory. Applications for Student Housing should be accompanied by a \$50 non-refundable processing fee. The total deposit is \$200 is due and payable when you accept the offered assignment. Tours of the housing facility are available through the UNM-LA Student Housing Office. For more

information, call 662-0333 or (800) 894-5919, ext. 333 (toll-free in NM).

Bookstore

The UNM-Los Alamos Campus Bookstore is located on the upper level of the Student Services Building. Normal business hours are 8:00 a.m. to 5 p.m. Monday through Friday. The telephone number is 505-662-0337. The Bookstore stocks textbooks listed as “REQUIRED” in a course syllabus and limited quantities of textbooks listed as “OPTIONAL” for lower division classes, community education classes and live Bachelor and Graduate Program classes. The Bookstore will not carry textbooks required for ITV or Distance Education classes. “USED” textbooks are usually available. The bookstore conducts a textbook buy-back for three days at the end of the fall and spring semester and two days at the end of the summer semester. Contact the store for specific details. Texts purchased for Short Term and Community Education classes may only be returned for refund twenty-four hours after the beginning of the class. It is the responsibility of the employee to pay for all purchases. A complete listing of required texts is available in the bookstore, and on the UNM-LA website home page. Click the bookstore link.

The UNM-LA Campus Bookstore Refund Policy allows for customers to return textbooks, for a 100% refund, until the end of the second week of instruction during the Fall and Spring semesters and the end of the first week for the Summer session. Books must be in original condition and accompanied by the receipt issued at the time of purchase. The Campus Bookstore conducts a textbook buy back three times a year. Three and one-half days at the end of the Fall and Spring semester and two days at the end of the Summer Session. Exact dates and times will be posted around campus via signage, the UNM-LA website and through instructor classroom notification. The Campus Bookstore carries a wide variety of drinks and snacks for your pleasure. We also carry a selection of UNM Lobo apparel. The Bookstore staff looks forward to serving you.

Library

The mission of the UNM-Los Alamos Library is to provide for the information needs of its students, faculty, and staff, and to contribute to the information resource base of the communities that it serves, through its resources (both traditional and electronic), services, staff, equipment, and facility. The Library, located in the Learning Center (east wing of Building 1), is a technologically advanced facility with wireless capability and 10 hard-wired public computing stations providing access to the Microsoft Office Suite, the Internet, LIBROS (the online catalog), a variety of academic databases and other online reference sources, and online collections of other libraries. The Library houses a growing collection of books, periodicals, pamphlets, maps, instructional videos, and sound recordings. The Library provides a pleasant, inviting setting for study, research, and the exchange of ideas. The main

floor of the Library offers a variety of comfortable study spaces appropriately dispersed throughout the facility, including carrels, study tables, three group study rooms equipped with white boards, computing stations, a periodical browsing area, and a reference resource area complete with additional carrels and a photocopier. A loft, upstairs from the main floor of the library, is a pleasant, airy space, which houses a distinctive Southwest Collection and provides a quiet area for study and instruction. The library team is friendly, knowledgeable, and very dedicated to helping library patrons with their information needs.

Changing art and book exhibits in the Library contribute to an aesthetically pleasing environment for all library visitors. For more information, link to our website through the UNM-LA home page at: www.la.unm.edu.

Adult Learning Center

The Adult Learning Center at UNM-Los Alamos provides adult basic education (ABE) services to adults over the age of 18 who wish to obtain their GED, brush up on their basic literacy skills, improve their workplace skills, or learn English as a second language (ESL). Classes are offered in the areas of reading, writing, math improvement, and ESL. Preparatory instruction for the GED exam is offered in English and in Spanish. Those between the ages of 16 and 18 may enroll with parental permission and proof of high school withdrawal. Preparatory instruction for the TOEFL (Test of English as a Foreign Language) exam is also offered to ESL students who wish to enroll in a US college or university. Books, materials, and individualized tutoring services are free, and there is no charge or fee for ABE classes.

Community Education

UNM-Los Alamos offers non-credit, short-term courses of an informational, educational, professional development, personal enrichment, and recreational nature. Whoever you want to be, whatever you want to do, whatever your career goals are, we do our best to help you get there! Courses are practical, time-sensitive, and user-friendly. Community Education has language programs, computer training, health education courses, in addition to many other areas of learning. CEU's are available for many courses. Community Education also offers programs for children during the summer, including Children's College, a “campus day-camp” for first- through sixth-graders and a “Writing Workshop” for 3rd through 6th graders.

Customized, Specialized and Technical Training

The Customized Training Program at UNM–Los Alamos works with area businesses to design low-cost, specialized training that meets employers’ needs and fits work schedules. Utilizing faculty resources from local, state and national pools, UNM–Los Alamos can design, develop, and deliver classes and certificate programs for the unique training needs of business or nonprofit/government organization at on-site or on campus to assist with identified training needs. Custom training is a cost-effective, targeted way to increase organizational effectiveness and enhance job skills and performance. The Customized Training Program also offers training through the New Mexico State Work Force Training Initiative.

Small Business Development Center

The UNM–Los Alamos Small Business Development Center (SBDC) is part of a national and statewide network that provides training and counseling services for small and start-up businesses. The UNM–Los Alamos SBDC offers no-charge business assistance to any existing or aspiring small business in the community, including not-for-profits. Business counseling and most of the training classes occur off campus at the Los Alamos Small Business Center. Counseling sessions are also held in the Jemez Springs area. The SBDC currently serves about 180-200 counseling clients each year. Typical areas of assistance include business start-up and registration, planning and business planning development, customer service, marketing, business financing, incorporation, proposal preparation, employee issues, business computing, record keeping, regulatory issues, quality management, productivity issues and trade name searches. A student can register online at www.nmsbdc.org To schedule a confidential appointment with a SBDC Business Counselor, call 662-001.

Contract Training

UNM–Los Alamos also offers contract training opportunities for northern New Mexico businesses and organizations. Through a training contract, the Los Alamos National Laboratory (LANL) and the University of New Mexico–Los Alamos are currently working together to provide state-of-the-art, up-to-date computer training to all lab and contract employees of LANL. This training contract provides desktop application training to increase these employees with job proficiency and career advancement opportunities. If any department at LANL identifies a particular need in their department that is not served by current course offerings (see website: <http://dat.la.unm.edu>), UNM–LA is able to work with them to design a course that meets their department’s specific needs. LANL employees or contract employees for LANL, can call for further information at 662-0346 or register online at <http://dat.la.unm.edu>.

College Cornerstone Program

The College Cornerstone program is designed to serve students by helping to strengthen their academic competencies as well as helping to ensure their successful transition into college level degree programs. The program offers course placement evaluation for students and Introductory Studies credit courses to help students enter college at the most appropriate level. Both the Tutorial Center and the Library work in conjunction with College Cornerstone faculty members to help provide educational opportunities and academic strategies for student success.

Admissions

General

The University of New Mexico-Los Alamos admits all eligible applicants from New Mexico, other states and foreign countries. Because of the great diversity of the University’s students, special application and admission procedures have been created to meet the needs of the different populations. UNM-Los Alamos serves recent high school graduates, transfer students, non-degree students, returning and nontraditional students. Admission procedures and requirements vary in each of the categories listed below. (Any applicant under the age of 16 must be reviewed by a special admissions committee.)

1. Beginning Freshmen (no previous college work)
2. Dual Enrollment (high school)
3. Concurrent Enrollment
4. Transfer Students (last attended another institution)
5. Readmit students (students who stopped attending for three or more sessions).
6. Non-Degree Students (presently not seeking a degree)
7. International Students

For all categories, the University requires full academic disclosure on the application forms. Any student found guilty of non-disclosure or misrepresentation on an application is subject to disciplinary action, including possible dismissal from the University. Transcripts and test scores submitted to UNM-Los Alamos for admission become the property of the University and will not be sent elsewhere or returned to the student.

Use of Social Security Numbers

Your Social Security Number will not be the primary University identification number. It will not appear on your Student identification card. UNM is required to collect your SSN in order to provide full access to services such as financial aid, to ensure an accurate academic record, and for record-keeping purposes. The University will protect the confidentiality of your SSN as required by law.

Beginning Freshmen

Associate Degree Admissions

A student may enroll in one of several associate degree programs offered by UNM-Los Alamos. The admission requirements for admission in an associate degree are a high school diploma or equivalent. A passing score on the General Education Development (GED) is accepted in lieu of a high school diploma. Special application and admissions procedures are in place to meet the varying needs of individuals seeking to enroll in educational programs at the institution. The UNM-Los Alamos campus has an open-admission policy. Admission is available to all students.

How to Apply

1. Applications may be submitted online or printed in hard copy at www.unm.edu. A \$10.00 non-refundable application fee is also required at the time that you submit your application and may be paid online or in person with the cashier.
2. Request that your high school or GED offices send an official transcript directly to the Student Services Office.

When to Apply

We strongly encourage students to apply as early as possible. Applications and fees are applicable for three consecutive sessions only. If you do not take advantage of admission and enroll within that period, a new application is required.

Other Admission Opportunities

Dual Credit Enrollment Option

This Dual Credit Program provides qualified public and charter school students to enroll in college-level courses offered by a public postsecondary educational institution that may be academic or career technical but not remedial or developmental, and simultaneously to earn credit toward high school graduation and a postsecondary degree or certificate. The program is designed to increase education opportunities, provide a college-level experience, and encourage more high school students to pursue higher education.

Meeting the criteria listed below does not mean that the student will be automatically admitted to the Dual Credit Program. In all cases, the final admission determination will be made by the UNM-LA Registrar's Office.

1. The student must have the certification and unconditional recommendation of the high school as well as proof of parental consent prior to participation on the Dual Credit/Concurrent Enrollment Application Form.
2. The high school must furnish the Office of Admissions with a current official high school transcript.
3. Cumulative grade point average of 2.50 or better on a 4.00 scale.
4. A student planning to enroll in English or Math must meet the minimum placement scores determined by UNM-Los Alamos in either the ACT, SAT or Compass tests.
5. A student planning to enroll in any course that has a prerequisite requirement must meet the minimum prerequisite or test score.

Students who have attended a non-accredited/non approved high school or home school may apply for Concurrent Enrollment.

Concurrent Enrollment

UNM-Los Alamos offers a Concurrent Enrollment Program for high school students who only want college credit. Eligible students must have a minimum GPA of 2.5 for academic course enrollment or a 2.0 GPA for vocation/technical enrollment. The student must have proof of parental consent prior to participation on the Dual Credit/Concurrent Enrollment Application Form. The high school must furnish the Office of Admissions with a current official high school transcript.

Introductory Studies Courses

Even though a student is qualified for admission to the University, he or she may be required to take one or more Introductory Studies courses. These courses are designed to strengthen a student's preparation for university-level work in areas of demonstrated weakness. Required enrollment in these courses is based upon established minimum standards of performance on individual tests or ACT or SAT scores and may be a requirement to receive the Bridge to Success Scholarship. Students required to take these courses should do so in their first semester(s) at UNM-Los Alamos and they must do so before they are eligible to proceed to other courses in those areas or to enroll in a degree granting program.

Transferring Students

How to Apply

1. Complete and return an application for admission and a \$10.00 nonrefundable application fee to the Student Services Office. You may also apply online at www.la.unm.edu.
2. Request that each college you have attended send an official transcript directly to the Student Services Office. A summary on one transcript of work at several colleges is not sufficient. If you are applying for the next academic session at UNM-Los Alamos while still enrolled at another institution, the official transcript must include a listing of courses in progress, as well as all completed work. (See note below.)
3. If you are transferring to UNM-Los Alamos with fewer than 26 semester hours of accepted college work, you are considered a freshmen transfer and must submit a complete official transcript of high school work or official GED scores.

Applications will not be processed until all the required items are on file with the Student Services Office.

To allow students at other institutions to make definite plans for transfer, a determination of admission status may be made before courses in progress are completed, subject only to receipt of the final transcript. Students permitted to register prior to receipt of their final transcripts may be disenrolled if their transcripts do not reach the Student Services Office within three weeks after the beginning of classes.

NOTE: The student must indicate on the application all previous college attendance. Applicants may not ignore any college attendance, even though they may prefer to repeat all courses. Students found guilty of nondisclosure or misrepresentation in filling out

admission application forms, or who find after admission or enrollment that for academic or other reasons they are ineligible to return to their last institution but fail to report this immediately to the Student Services Office, are subject to disciplinary action, including possible dismissal from the University.

When to Apply

We strongly encourage students to apply as early as possible. If you do not register for the session requested on your application and wish to postpone enrollment to a subsequent semester, you must notify the Student Services Office. Applications and fees are applicable for three consecutive sessions only. If you do not take advantage of admission and enroll within that period, a new application and fee are required.

Admission Requirements

UNM-Los Alamos operates on a semester credit calendar. Therefore, classes from quarter system institutions will be recalculated to semester hours (one quarter hour equals .66 semester hour). Applicants with fewer than 26 transferable hours are considered transferring freshmen and must therefore submit high school credentials and meet freshmen admission requirements (see Beginning Freshmen above).

Previous Suspension

A student **under academic suspension** from another college or university may not enter UNM-Los Alamos during the term of suspension. In cases of unspecified suspension periods, the University's suspension term will apply. Upon termination of the suspension, the student is eligible to request special consideration for admission to UNM-Los Alamos. In general, students **under disciplinary suspension** are not admitted to UNM-Los Alamos. However, because the reasons for disciplinary suspension vary among institutions, a student may be suspended from one school for infractions that would not be actionable at another. Therefore, UNM-Los Alamos reviews such cases individually and, when justified, makes exceptions and allows the student to be considered for admission.

Transfer of Credits

UNM-Los Alamos evaluates without prejudice courses from postsecondary institutions that are regionally accredited or are candidates for regional accreditation. Transfer students will receive full credit for course work completed with a minimum grade of "C," provided the classes are similar or equivalent to courses offered at the University. (Transferable courses with grades of "D" from New Mexico state institutions are accepted.)

UNM-Los Alamos does not accept personal development or dogmatic religion courses. Credit is not awarded for work or life experience, cooperative education or for courses from out-of-state in which the grade received was lower than "C." Grades earned in courses taken at other institutions are not included in calculation of the UNM grade point

average. This grade point average will reflect only classes taken at UNM.

Transfer Among New Mexico Higher Education Institutions

To facilitate transfer of students and course credits among New Mexico's colleges and universities, the state's public institutions of higher education are required to accept in transfer courses taken within approved modules of lower division course work and apply them toward degree requirements. Several transfer guides have been developed through collaboration of New Mexico's public postsecondary institutions, consistent with requirements of state law (21-1B, NMSA 1978). Students enrolling for first-year or second-year study at a New Mexico institution and wishing to prepare for possible transfer into a degree program at another institution are advised to take these courses during their freshman and sophomore years.

Student Responsibility

New Mexico's colleges and universities have collaborated to produce guides to assist students who plan to transfer before completing a program of study. Course modules are designed to help students select courses carefully so that they may transfer with little or no loss of credit. However, planning for effective transfer with maximum efficiency is ultimately the student's responsibility. Responsible transfer planning includes early and regular consultation with the intended degree-granting institution to assure that all pre-transfer course work will meet the requirements of the desired degree.

Transferable Lower-Division General Education – Common Core

For students enrolled at any public institution in New Mexico, the following courses are guaranteed to transfer to any other New Mexico public college or university and apply toward associate and baccalaureate degree program requirements. Students should consult advisors at their current institution regarding which specific courses fit these categories. Students preparing for careers in engineering, health sciences or other profession-related fields are advised that some of this course work may not transfer toward general education requirements but in most cases will apply toward elective requirements.

Area I: Communications	9 semester hours
(a) College-Level English Composition	3-4 hrs.
(b) College-Level Writing	3 hrs.
(a second course building on the above)	
(c) Oral Communications	3 hrs.
Area II: Mathematics and Statistics	9 semester hours
(a) College Algebra	3 hrs.
(b) Calculus	3 hrs.
(c) Other College-Level Mathematics and Statistics	3 hrs.

Area III: Laboratory Science	8 semester hours
(a) General Biology w/lab	4-8 hrs.
(b) General Chemistry w/lab	4-8 hrs.
(c) General Physics w/lab	4-8 hrs.
(d) Geology/Earth Science w/lab	4-8 hrs.
(e) Astronomy w/lab	4-8 hrs.
Area IV: Social/Behavioral Sciences	6-9 semester hours
(a) ECON. (macro or micro- economics)	3 hrs.
(b) Introductory Political Science	3 hrs.
(c) Introductory Psychology	3 hrs.
(d) Introductory Sociology	3 hrs.
(e) Introductory Anthropology	3 hrs.
Area V: Humanities and Fine Arts	6-9 semester hours
(a) Introductory History Survey	3 hrs.
(b) Introductory Philosophy	3 hrs.
(c) Introductory Course in History, Theory or Aesthetics of the Arts or Literature	3 hrs.
Totals to be selected	35 semester hours

Transferring Courses to Fulfill the New Mexico General Education Common Core

During the 2005 New Mexico Legislative session, Senate Bill 161, consistent with requirements of state law (Chapter 224 of the Laws of New Mexico, 1995, as amended) was signed into law to further enhance and facilitate the articulation of general education courses among New Mexico's colleges and universities. In accordance with policies established by the New Mexico Higher Education Department, designated general education core courses successfully completed at any regionally accredited public institution of higher education in New Mexico are guaranteed to transfer to any New Mexico public institution. Students who have decided on a major and/or an institution at which to complete their studies should consult with an academic advisor at that particular institution to determine the most appropriate course selections. Students enrolling for the first-year study at a New Mexico college or university and considering possible transfer into a certificate and/or degree program at another institution are encouraged to take the courses approved for transfer during their freshman and sophomore year of study.

The core matrix of approved courses guaranteed to transfer and meet general education

requirements at any New Mexico college or university can be found on the New Mexico Higher Education Department website at <http://www.hed.state.nm.us>. Follow the “Colleges and Universities” link to the drop down menu and select “Transferring Credits”, then select “Core Matrix”. Courses are listed by institution, whether university or community college, under each of the five general education areas. Students may also be able to access this list by going directly to <http://www.hed.state.nm.us/colleges/matrix.asp>

The course prefix and number that appear in parenthesis next to many of the institutions’ internal course prefixes and numbers is the New Mexico Common Course Number. This is a four-alpha/four-numeric set of uniform course designations that serve as a single reference point for courses taught throughout the state that share substantially equivalent content. Courses bearing this designation are part of a statewide equivalency table that cross-references the institutional course and number with the universal “common course number” creating an easy one-to-one match.

Students may find the New Mexico Common Course Number listed in crosswalks, degree outlines, transfer guides, and in course descriptions in college catalogs and websites. Simply put, the common course number connects equivalent courses at multiple institutions ensuring students that the course will transfer to the receiving institution, and meet degree requirements as if it were taken on that campus.

The New Mexico Common Course Number has an alpha prefix that identifies readily to the subject area. The four digits in the number represent the specific course in that subject area with each digit having significance as demonstrated below:

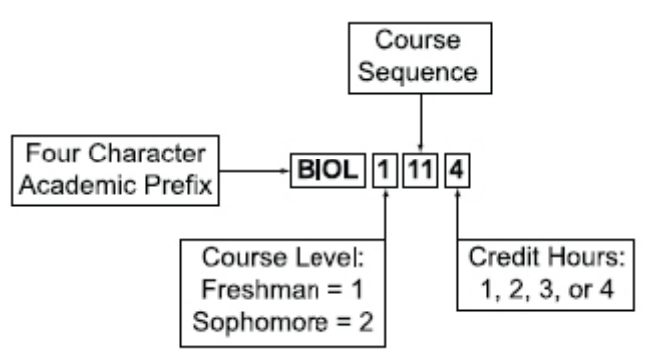

Inter-Institutional Transfer Guides and Catalogs

Students who have selected a field of study and/or the institution where they wish to graduate are advised to consult the transfer guide or catalog for that institution for more current and detailed advice to guide their course selection. Formal published transfer guides

between The University of New Mexico and Central New Mexico Community College, Clovis Community College, Diné College, Eastern New Mexico University–Roswell, Luna Community College, Mesalands Community College, New Mexico Junior College, New Mexico Military Institute, New Mexico State University–Alamogordo, Carlsbad and Grants, Northern New Mexico College, San Juan College, Santa Fe Community College and Southwestern Indian Polytechnic Institute are available in The University of New Mexico Admissions Office and on the Web at www.unm.edu.

Complaint Procedure for Transfer Students

All New Mexico public post-secondary institutions are required to establish policies and practices for receiving and resolving complaints from students or from other complainants regarding the transfer of course work from other public institutions in the state. A copy of The University of New Mexico’s complaint policy may be obtained from the Admissions Office or from the New Mexico Higher Education Department, 1068 Cerrillos Road, Santa Fe, NM 87501-4295, (505) 827-7383 (www.hed.state.nm.us).

Evaluation of Credit

The evaluation of credit is ordinarily part of the admissions application procedure for students entering an associate program. It is a two-step process. An Admissions Officer first evaluates credits on a course-by-course basis to determine general transferability to the University, and a transfer evaluation is produced for students who are admitted. (Students who have completed courses in institutions utilizing non-traditional credit or grading systems may be required to provide additional information to facilitate the evaluation.) The student must contact an academic advisor in order to determine how the transferred courses will be applied to a degree.

Readmitted Students

A UNM-Los Alamos degree-seeking student who stops attending for **three or more sessions, including summer**, must file an application for readmission. You may also apply over the Web at www.la.unm.edu. The application fee is not required.

1. Complete and return an application for readmission.
2. If you attended another institution while away from UNM Los Alamos or have taken college level correspondence or extension courses, send an official transcript from each college you have attended directly to the Student Services Office. A summary on one transcript of work at several colleges is not sufficient. If you are applying for the next academic semester at UNM-Los Alamos while still enrolled at another institution, the official transcript must include a listing of courses in progress, as well

as all completed work. Applications will not be processed until all the required items are on file with the Student Services Office.

3. Readmissible students with fewer than 26 semester hours or undecided about their major will ordinarily enroll in an associate degree program. Students with more than 26 semester hours, with an area of interest or a definite major in mind should refer to the appropriate program section of the catalog.
4. Students who have been suspended or dismissed as the result of disciplinary problems shall not be readmitted to the University without a required interview with the Director of Student Services. The University reserves the right to refuse any student readmission on the basis of his or her student history, either academic or disciplinary.

When to Apply

We strongly encourage students to reapply as early as possible. Deadlines for readmission vary according to your previous academic status or the college you wish to enter. Contact the Student Services Office for specific dates. If you do not register for the session requested on your application and wish to postpone enrollment to a subsequent semester, you must notify the Student Services Office. Applications are applicable for **three consecutive sessions only**. If you do not take advantage of admission and enroll within that period, a new application is required.

Alternative Credit Programs

UNM-Los Alamos grants college credit for certain outside training, courses and examinations. In all cases, students must be enrolled in undergraduate degree status. The guidelines for each of these programs are as follows:

Technical Credit

Under special circumstances, students may receive credit for technical courses that are not normally transferable to UNM-Los Alamos. Students who have earned technical credit which they believe may be applicable to their specific degree programs can request a review of that credit by the department chairperson or program director. An interview or demonstration of competence, or both, may be required before a decision regarding credit is made. Acceptance of technical credit is binding only to the specific department or program recommending the credit.

Training Credit

Credit for noncollegiate training programs is granted based on recommendations of the American Council of Education's "National Guide to Educational Credit for Training Programs" and institutional policies. Official records must be supplied to The University of New Mexico-Los Alamos Office of Student Services by the appropriate source.

Military Credit

Credit for military service is granted based on recommendations of the American Council of Education's "Guide to the Evaluation of Educational Experiences in the Armed Service" and institutional policies. No credit is granted for Military Occupational Specialty (MOS).

When to Apply

We strongly encourage students to reapply as early as possible. Deadlines for readmission vary according to your previous academic status or the college you wish to enter. Contact the Student Services Office for specific dates. If you do not register for the session requested on your application and wish to postpone enrollment to a subsequent semester, you must notify the Student Services Office. Applications are applicable for **three consecutive sessions only**. If you do not take advantage of admission and enroll within that period, a new application is required.

Non-degree Credit Programs

The Non-Degree credit program allows students to earn academic credit without being admitted into a degree-granting unit. This program accommodates non-traditional students who wish to begin taking academic courses to prepare for graduate studies, career changes or for professional and/or personal development. Non-Degree status is recommended for visiting students from other institutions.

How to Apply

Apply online by clicking [here](#) or complete and return a non-degree admission application and a \$10.00 fee to:

Registrar
UNM-Los Alamos Student Services Office
4000 University Drive
Los Alamos, NM 87544

When to Apply

Students are encouraged to submit their applications as early as possible. If you do not register for the session requested on your application and wish to postpone enrollment to a subsequent semester, you must notify the Student Services Office. Applications are applicable for three consecutive sessions only. If you do not take advantage of admission by enrolling within that period, a new application and fee are required.

Admission Requirements

You must be 21 years of age or older or if you are under 21:

a. Your high school graduating class must have been out of school for at least one full year;

- or -

b. If you earned your diploma by the GED exam, your graduating class must have been out of high school at least one year.

NOTES:

1. Students in Non-Degree status are not eligible to receive financial aid. Contact the Financial Aid Office at (505) 661-4692 for details.
2. Veterans planning to attend the University under one of the public laws governing veterans' educational benefits and who are seeking admission to Non-Degree are required to have special approval from the Financial Aid Office (505) 661-4692.

The following students are not eligible for Non-Degree status:

1. A student who is under disciplinary or academic suspension from UNM-Los Alamos or any other collegiate institution.
2. A student who has exhausted his or her eligibility in University College and is not academically eligible to enter a degree-granting college at The University of New Mexico.
3. A student who has not completed a degree and was previously enrolled in degree status in an undergraduate college at The University of New Mexico.
4. A student from another country who is in the United States on a student visa.
5. A student who has been refused admission to degree status.
6. A student planning to receive student financial aid.

Applicants for Non-Degree status are required to certify that they are not under suspension from any college or university. Students found guilty of nondisclosure or misrepresentation in filling out the admission application form or who after admission or enrollment at UNM-Los Alamos are found to be ineligible for academic or other reasons to return to the last institution attended and fail to report this immediately to the Student Services Office, will be subject to disciplinary action, including possible dismissal from the University.

Facts about Non-Degree Status

1. A one-time \$10.00 application fee is required.
2. No transcripts of previous high school or college work are required for admission. NOTE: A transcript may be required to determine fulfillment of prerequisite course work.
3. There is a 30 credit hour limit in Non-Degree status if you do not have a baccalaureate degree. There is no limit for students with a baccalaureate degree.
4. Credits earned in Non-Degree are recorded on a University of New Mexico permanent record. Credits may be applied to an undergraduate plan of study, if the courses meet specific degree requirements.
5. If you are planning to take education courses, you must contact the College of Education at (505) 277-3190 concerning requirements.
6. Non-degree students applying for undergraduate degree status must follow admission procedures and provide all items required of transfer students (see Transferring Students).

Academic Standards

Students in Non-Degree are subject to all University regulations governing registration, attendance, academic standing and satisfactory completion of prerequisite courses. The Albuquerque campus Non-Degree Student Services Office governs academic standing and maintains college records for all Non-Degree students, including those at branch campuses and Extended University sites.

Non-Degree Status Limitations

Students without a baccalaureate degree may earn no more than 30 semester credit hours in non-degree status. No undergraduate college of the University will accept in a degree program more than 30 semester hours earned while the student is in non-degree status nor is a college obligated to accept any hours earned in non-degree status that do not fulfill college degree requirements. If degree status is not attained prior to earning 30 semester hours, the student will be allowed to register in courses in non-degree status as an auditor

only, receiving no credit.

Normally a non-degree student may not enroll for more than 9 semester hours during a regular session without special permission. Contact the UNM-LA Student Services (662-0332) to discuss enrollment limitations and options. **This limitation does not apply to a student who has earned a baccalaureate or higher degree nor to a visiting student.** The senior residence requirement cannot be met by enrolling in non-degree status. This can be accomplished only by enrolling in a degree-granting college of the University.

A non-degree student who does not have a baccalaureate or equivalent degree may not enroll in 500-600 level courses. Non-degree students normally may enroll only in undergraduate credit offerings. In some cases graduate credit course work earned while in non-degree may apply to a graduate degree. Contact the specific department for details.

Non-Degree Advisement Office

Non-Degree advisement is part of the University College Advisement Center, located in the Student Services Center in Albuquerque, Rm. 114.

Phone: (505) 277-2631

FAX: (505) 277-3173

E-mail: ucac@unm.edu

The Advisement Center provides the following services for Non-Degree students:

- Academic Advisement
- Registration Assistance
- Orientation Sessions for New Students
- Extended Office Hours
- Referrals to Campus Services

International Students

The University of New Mexico welcomes applications from international students who have earned distinguished academic records and have demonstrated English proficiency. The University is proud to claim one of the most ethnically diverse student bodies among universities anywhere in the United States. The academic programs consistently rank among the top in universities across the United States, and the faculty is distinguished by Nobel Laureates, Fulbright recipients and nationally recognized academicians.

International Non-Degree Admission

1. International students wishing to enroll at UNM-Los Alamos in Non-Degree Status must submit an admission application which includes Visa Type and Country of Citizenship information.
2. Students taking non-academic courses may not be required to provide copies of documentation or proof of English Proficiency with the admission application.
3. Students interested in taking an academic course will be required to obtain instructor approval or provide proof of English proficiency.
4. Please contact the UNM-Los Alamos Registrar at (505) 661-4688 for guidance and more information.

International Undergraduate Admission Requirements

1. **Secondary Education:** Completion of the equivalent of an American upper secondary school education (approximately 12 years of formal education beginning at age six) as well as the appropriate diplomas and/or satisfactory results on leveling examinations.
2. **Academic Preparation:** Strong academic preparation or a U.S. equivalent grade point average of 2.5 on a 4.0 scale (for freshman applicants) or 2.0 on a 4.0 scale (for transfer students).
3. **English Proficiency:** If English is not the first language of the student or not the official language of the country, the student must submit results of either the International English Language Testing System (IELTS) - minimum score 6.5; the Test of English as a Foreign Language (TOEFL) - minimum score 520 paper-based or 190 computer based; the University of Cambridge Examinations Certificate of Proficiency in English (CPE) or Certificate of Advanced English (CAE) - minimum score C. Students who are academically admissible but whose scores are less than the required minimum may enroll in the intensive English program offered through UNM's Center for English Language and Culture (CELAC). Contact the Office of International Programs and Studies (oips@unm.edu) for additional information. Transfer students who have satisfactorily completed the equivalent of The University of New Mexico's two freshman English composition courses (ENGL 101 and 102) at accredited U.S. institutions are not required to submit English proficiency results scores.
4. **Financial Resources:** All international applicants seeking a degree are required to submit documentation verifying adequate funding to meet study and living expenses while in the United States. A minimum amount of approximately \$27,000 U.S. dollars is required (based on 2004–2005 rates). Proof of support includes a Certification of Financial Responsibility Form completed for all years of study and proof of funds

available for the first year of study.

- 5. Health Insurance:** International students who attend The University of New Mexico and any dependents who may accompany them are required to have medical insurance as offered through The University of New Mexico. Students who demonstrate that they have equivalent health insurance policies may be granted waivers.

Required Documents

- 1. Completed application form.**
Students must submit an application for International Undergraduate Admission to the Office of International Admissions. Students may also apply online at www.unm.edu.
- 2. \$50.00 non-refundable application fee**
(Must be in U.S. currency and paid by International Postal Money Order or certified check drawn on a U.S. bank.)
- 3. Evidence of English language proficiency**
Test scores must be sent directly to the University from IELTS at www.ets.org
- 4. Academic Records**
In order to facilitate the admission decision, The University of New Mexico strongly recommends that students initially submit academic records to any member of the National Credential Evaluation Services <http://www.naces.org>). Students must still submit official transcripts to the University, but the English translations will not be required. Students who do not utilize a credential evaluation service must have official grade reports (transcripts) and diplomas or certificates from each institution attended sent to The University of New Mexico. Students must submit original or officially certified copies. Notarized, faxed copies or photocopies of these documents are not acceptable. All documents must be submitted in both the original language accompanied by an official certified English translation. Certified copies must contain the original signature(s), stamp(s) or seal(s) of the issuing institution's designated official. Students who have no prior college or university credit must submit evidence of graduation from an acceptable secondary school and must be eligible for admission university in their home countries.
Note: A student who wants any information concerning the applicant file released to any third party must submit a letter of authorization directly to the International Admissions Office. This release must include the student's name and signature.

Application Deadlines

Submit all documents to:

International Admissions Office of Admissions

MSC06 3720

1 University of New Mexico

Albuquerque, NM 87131-0001

PLEASE NOTE: I-20 Statement

The Immigration Form I-20 is valid up to the first day of class for the semester or summer session to which a student is admitted. Students that are not able to attend must immediately return the I-20 form to the International Admissions Office. A \$50 non-refundable deposit is required before the I-20 will be issued. It is later applied to tuition. If a student does not enroll or changes semesters, the deposit is forfeited.

International Undergraduate Readmitted Students

A University of New Mexico degree-seeking student who stops attending for consecutive sessions must file an application for readmission. You may also apply on the Web at www.unm.edu. If you have attended another institution since your last attendance at the University, you must also submit new, official transcripts. In addition, you must update your financial documentation.

Undergraduate Admissions

General Academic Regulations

Students are responsible for complying with all regulations of the University, their respective colleges and the departments from which they take courses, as well as for fulfilling all degree requirements. Students are responsible for knowing and complying with all academic regulations.

Core Curriculum

The University has adopted a revised Core Curriculum as of Fall 2003 which all undergraduate students must complete as part of their baccalaureate program. The Core consists of several groups of courses designed to enhance each student's academic capabilities. Its goal is to give all students at the University a grounding in the broad knowledge and intellectual values obtained in a liberal arts education and to assure that graduates have a shared academic experience. The required courses encourage intellectual development in seven

areas of study: writing and communication, social and behavioral sciences, mathematical reasoning, scientific methods in the physical and natural sciences, the humanities, the fine arts, and languages. The Core consists of lower-division courses which develop these skills and abilities, and students are strongly encouraged to complete the Core early in their college careers. Individual student substitutions should be minimal and are discouraged. Except where noted (see “Alternative Credit Options” in the Undergraduate Admissions section of the Catalog), students may apply AP or CLEP credit to the Core requirements.

Departments and colleges may restrict student choices within the Core to meet departmental and college degree requirements. A grade of C (not C-) is required in all courses used to fulfill the requirements of the Core Curriculum. Courses taken CR/NC can be applied to the core, subject to general University and individual college and department regulations on the number of credits that can be taken CR/NC and the applicability of courses taken CR/NC to the individual degree.

The University recognizes, however, that the highly structured nature of many degree programs and the presence of numerous transfer and non-traditional students requires flexibility on its part. Transfer and reentering students will receive advising in the college and department to which they are admitted in order to establish an appropriate program which will meet their needs and the aims of the Core. Where degree program requirements are so structured that a student’s total academic program credits would be increased by taking a Core course in a particular Core area, a department may approve a blanket substitution of a course in a particular Core particular program. Approval of substitutions or exceptions is handled on a department and college basis. The basic Core Curriculum requires approximately 37 hours of courses in seven areas of study.

- 1. Writing and Speaking (9 hours):** English 101 and 102 plus an additional course chosen from English 219, 220; Communication and Journalism 130; Philosophy 156. Students with ACT English scores of 29 and higher or SAT Critical Reading scores of 650 or higher have satisfied the University Writing Requirement and should enroll for courses of their choice in the Writing and Speaking Core. Students with ACT English scores of 26, 27, 28 or SAT Critical Reading scores of 610 or higher may enroll directly in English 102 and, upon passing, meet the University Writing Requirement. Students with ACT English scores of 25 or lower or SAT Critical Reading scores below 610 should enroll in English 101. Students who have taken an Advanced Placement examination in English Language or Literature should refer to “Advanced Placement” for placement and credit information.
- 2. Mathematics:** One course chosen from Math 121, 129, 150, 162, 163, 180, 181, 215, Stat 145.
- 3. Physical and Natural Sciences:** Two courses, one of which must include a laboratory, chosen from Anthropology 150 and 151L, 121L (lab required), 160 and 161L; Astronomy 101 and 101L; Biology 110 and 112L, 123 and 124L; Chemistry 111L (lab required), 121 and 123L (lab required) or 131L (lab required), 122 and

124L (lab required) or 132L (lab required); Earth and Planetary Sciences 101 and 105L, 201L (lab required); Environmental Science 101 and 102L; Geography 101 and 105L; Natural Sciences 261L (lab required), 262L (lab required), 263L (lab required); Physics 102 and 102L, 105, 151 and 151L, 152 and 152L, 160 and 160L, 161 and 161L.

- 4. 4. Social and Behavioral Sciences (minimum 6 hours):** Two courses chosen from American Studies 182, 185; Anthropology 101, 130; Community and Regional Planning 181; Economics 105, 106; Engineering-F 200; Geography 102; Linguistics 101 (AOA Anthropology 110); Political Science 110, 200, 220, 240; Psychology 105; Sociology 101.
- 5. Humanities (6 hours):** Two courses chosen from American Studies 186; Classics 107, 204, 205; Comparative Literature and Cultural Studies 223, 224; English 150, 292, 293; Foreign Languages (M Lang) 101; History 101L, 102L, 161, 162; Honors Legacy Seminars at the 100- and 200-level; Philosophy 101, 201, 202; Religious Studies 107, 263, 264.
- 6. Foreign Language (non-English language; minimum 3 hours):** One course chosen from any of the lower-division non-English language offerings of the Departments of Linguistics (including Sign Language), Spanish and Portuguese, Foreign Languages and Literatures, and foreign languages in other departments and programs.
- 7. Fine Arts (minimum of 3 hours):** One course chosen from Architecture 101; Art History 101, 201, 202; Dance 105; Fine Arts 284; Media Arts 210; Music 139; Theatre 122. Students may elect to take one 3-hour studio course offered by the Departments of Art and Art History, Music, Theatre and Dance, and Media Arts to fulfill this requirement.

Graduation Requirements

Associate Degrees

Candidates for associate degrees offered by any of The University of New Mexico’s colleges or branches must meet the following minimum degree requirements and are subject to the following University limitations:

1. A minimum of 60 acceptable semester hours must be earned. Technical work (up to the limit specified below) may be included in these 60 hours, upon approval of the appropriate degree-granting college.
2. A minimum of 15 semester hours must be earned in residence at The University of

New Mexico, exclusive of extension and correspondence credits. The remainder may be acceptable transfer credits earned at fully accredited institutions of higher learning and/or at regionally accredited technical-vocational institutions (see also Transferring Students for transfer credit regulations).

3. Of the 60 hour minimum, no more than 9 semester hours may be earned by extension or correspondence.
4. The student must have a cumulative grade point average of at least 2.00.
5. Introductory Studies 100 courses may not be used to satisfy any of the above requirements.

Certificates

Candidates for certificates offered by any of The University of New Mexico's colleges or branches (except EMT) must meet the following minimum requirements and are subject to the following University limitations:

1. A minimum of 30 acceptable semester hours must be earned. Technical work (up to the limit specified below) may be included in these 30 hours upon approval of the certificate-granting program.
2. A minimum of 15 semester hours must be earned in residence at The University of New Mexico-Los Alamos.
3. Of the 30 hours minimum, no more than 6 semester hours may be earned by extension or correspondence.
4. The student must have a cumulative grade point average of at least 2.00.

Second Certificate/Associate Degree

A second certificate or a second associate degree will not be granted until a student has earned a minimum of 15 semester hours in residence above the requirements for the first certificate or degree and fulfilled all requirements for the second certificate or degree including residence requirements.

Extension and Independent Study

The University of New Mexico allows credit for independent study, correspondence and extension courses at the University of New Mexico or through other fully accredited

colleges and universities toward degree requirements. Credit for extension and independent study courses completed at institutions not accredited by regional accrediting associations is not accepted for transfer, although a student who has completed such correspondence or extension work in a course comparable to one at the University of New Mexico may establish credit here by special examination (see Examinations).

The hours earned by independent study or extension from accredited institutions other than the University of New Mexico may be counted toward degree requirements, but the grades will not be included in the student's grade point average (see Grade Point Average). Courses taken from other institutions must correspond to those offered at the University of New Mexico. Any graduating student who expects to substitute credits earned by independent study toward fulfillment of degree requirements must have prior approval of his or her college's dean. The student is responsible for complying with all regulations stated in the Independent Study Guidelines.

Cooperative Education and Internships

The Cooperative Education and Internship program provides UNM-Los Alamos students from various academic disciplines with an opportunity to work in a field related to their major. The work should allow students to apply theories learned in the classroom to "real world" experiences. The work provides an opportunity to earn course credit. More information on Cooperative Education is available from the Student Services Office located in the lower level of Building 2.

Catalog Requirements

Undergraduate students may graduate under the requirements in the catalog issue in effect at the time of their admission into the college or school from which they are seeking a degree. If students transfer from one degree-granting college or program to another within the University, they must comply with the catalog requirements in effect at the time of their transfer.

Nonwithstanding the above, The University of New Mexico-Los Alamos reserves the right to make changes in the curricula and degree requirements as deemed necessary, with the changes being applicable to currently enrolled students.

Readmission

Students who interrupt their degree program and are not enrolled for three or more consecutive semesters (including Summer), must comply with catalog requirements in effect at the time of reenrollment.

Responsibility for Requirements

Students are responsible for knowing the rules and regulations concerning graduation requirements and for registering in the courses necessary to meet them. Advisement at the specific department/program level is strongly recommended to assure timely graduation. Students who take more than 10 years to graduate from the date of their original admission, must conform to the catalog in effect in the semester in which they intend to graduate.

Commencement

Commencement exercises are held once per year, at the end of the spring semester. Attendance is optional. Students whose requirements were completed and degrees conferred in the preceding summer session, fall or spring semester are invited to attend.

Executive Director's List

UNM-Los Alamos students who demonstrate academic excellence are honored by inclusion in the Dean's List. Students are selected based on the following criteria:

1. Part-time students (6-11 hours) must complete a minimum of 6 undergraduate credit hours at UNM-LA with regular grading option in a given semester.
2. Full-time students must complete a minimum of 12 undergraduate credit hours at UNM-LA with a regular grading option in a given semester.
3. A semester Grade Point Average (GPA) of 3.5 is required.
4. No grade lower than a "C" (not "C-") is acceptable.
5. Students in Non-degree or Graduate status are ineligible for consideration.

New Mexico/WICHE

(Western Interstate Commission for Higher Education) Since 1951, New Mexico has sponsored and sent students across state lines to receive professional education. The 13 western states have provided this service under terms of the Western Regional Education Compact, which has been adopted by the legislatures of all 13-member states and has been administered by the Western Interstate Commission for Higher Education.

New Mexico participates in 11 of the 15 disciplines offered through WICHE Professional Student Exchange. Certified New Mexico residents are eligible for funding support at WICHE participating institutions in the fields of dentistry, veterinary medicine,

occupational therapy, optometry, osteopathy, physician assistant, masters of physical therapy, podiatry, nursing, graduate library studies and public health. In addition, New Mexico receives WICHE students from the other compacting states in the fields of medicine, physical therapy, law, pharmacy and architecture.

Student Services Information

Records

The Student Services Office is responsible for the maintenance of the educational records at UNM-Los Alamos. This includes, but is not limited to, student transcripts, academic folders and faculty grade reports. The following information refers to some of the policies and procedures for educational records. Please Note: proper photo identification (driver's license, Lobo Card, passport or other state issue identification) is required for all in-person transactions.

Use of Social Security Numbers

The Social Security Number (SSN) is not the primary University identification number. UNM is required to collect SSN in order to provide full access services such as financial aid, to ensure and accurate academic record, and for record-keeping purposes. The University protect the confidentiality of SSN as required by law.

Access to and Confidentiality of Student Records

Family Educational Rights and Privacy Act (FERPA) November 19, 1974

Student Record Policy

1. Introduction

Under the Family Educational Rights and Privacy Act of 1974 (FERPA), students have the right to inspect and review most education records maintained about them by the University of New Mexico, and, in many cases, decide if a third person can obtain information from them. Nine categories of information, however, are public

(or directory information) unless a student asks that some or all of that information be withheld. It is the policy of the University to comply fully and fairly with the provisions of the Act, Federal Regulations and this policy.

2. **Limitations on Access to Student Records**

No one inside or outside the University shall have access to, nor will the contents of students' education records be disclosed without the written consent of the students except as provided by the Act and Regulations. Exceptions in the Act and Regulations include but are not limited to the following: personnel within the institution determined by the institution to have a legitimate educational interest, officials of other institutions in which students seek to enroll or are enrolled, persons or organizations providing student financial aid, accrediting agencies carrying out their accreditation function, persons in compliance with judicial orders and persons in an emergency when necessary to protect the health or safety of students or other persons.

3. **Students' Right of Access to Review Their Records**

A student has the right to inspect and review all education records about him or her except: (1) personal notes (available only to writer or substitute) of University staff and faculty, (2) certain student employment records, (3) counseling records used solely for treatment, (4) certain records of the University Police, (5) parents' financial records, (6) confidential letters and statements of recommendation placed in the records before January 1, 1975, and (7) confidential letters and statements of recommendation for admission, employment, or honorary recognition placed in the records after January 1, 1975, which students have waived the right to inspect and review.

4. **Informing Students of Their Rights**

This policy will be published in the *UNM Pathfinder* or its successor.

5. **Location of Student Records**

Student records are not maintained in a central location. Instead, these records are maintained by each office with which a student has contact while enrolled at the University. A partial list of places where educational records are maintained by various University offices is listed below.

- Admissions Office, Director of Admissions, Student Services Office
- Career Counseling and Placement, Director, Career Counseling and Placement, Student Services Office
- Cashiers and Student Accounting, Bursar, Student Services
- Dean of Students Office, Associate Vice President and Dean of Students, Student Services

- Graduate Studies, Dean, Graduate Studies, Humanities Building
- Housing Services, Director of Finance, Building 1
- Records and Registration Office, Registrar, Student Services Office
- Financial Aid Manager, Student Financial Aid Office, Student Services, Building 2.

6. **Records Excluded from the Definition "Education" or "Student" Records**

The following categories of records are not included in the term "education records" or "student records" under the Act:

- 6.1. Records of instructional, supervisory, administrative and certain educational personnel which are in the sole possession of the maker and are not revealed to any other individual (except a substitute who performs on a temporary basis the duties of the person who made the record).
- 6.2. Records of the University Police. These records are maintained and created by the University Police Department for the purpose of law enforcement. Their disclosure is subject to rules and regulations of the University Police, consistent with applicable law.
- 6.3. Records relating to individuals who are employed by the University which are made and maintained in the normal course of business, relate exclusively to individuals in their capacity as employees and are not available for use for any other purpose. However, it should be noted that records of individuals in attendance at the University who are employed as a result of their status as students are education records and as such may be inspected by the student.
- 6.4. Records which contain only information about a person after that person is no longer a student at the institution, e.g., information gathered on the accomplishments of alumni.

7. **Review Policies and Procedures**

Requests to inspect and review records must be made, in writing, to the office that keeps the records. Although it is the University's policy that requests to inspect records be honored as promptly as possible, the offices have up to 45 days to honor such requests. It is the policy of the University to provide the student upon request with photocopies of her or his records where that will help the student in inspection and review of the records unless: (1) the record to be copied is an examination, in which case permission of the faculty member is necessary, or (2) where a student's record is being withheld because of an outstanding financial obligation to the University. Fees for photocopies of materials in the records are the same as University offices charge for photocopies of other materials. At its option, an office may furnish copies at no charge, or take the materials to a copy/duplicating center on campus,

8. **Release Policies and Procedures, University Employees and Agents**

The University will not disclose personally identifiable information from a student's education record without the student's written consent, except when it is permitted by the Act and Regulations. As permitted by the Act and Regulations, information

will be disclosed without the student's consent to University officials with a legitimate educational interest. These officials or their agents, and their interests, include:

8.1. Any University employee who needs the information to fulfill job responsibilities.

8.2. University collection agents only for the purposes of collecting debts owed to the University.

8.3. Legal counsel advising or representing the University.

8.4. National Collegiate Athletic Association and the Mountain West Athletic Conference only for the purposes of conforming to eligibility rules for athletic competition.

8.5. Contractors, such as data processing, only for the purposes of performing work under contract for the University.

8.6. Honorary societies, and other chartered student organizations, only for determining membership eligibility/requirements, when the societies and/or organizations do not unlawfully discriminate on the basis of race, color, religion, national origin, physical or mental disability, age, sex, sexual preference, ancestry, or medical condition.

8.7. University researchers, including students doing research under supervision of a faculty member, if there are safeguards to protect the security of personally identifiable data and if it will not be possible to ascertain the identity of any student in any dissemination of the data or research results.

8.8. Officials of cooperating universities in which the student is enrolled.

9. Release to Alleged Victims of Crimes of Violence

The results of any disciplinary proceeding conducted by the University in response to allegations of a crime of violence allegedly committed by a student, shall be disclosed upon request to the alleged victim(s) of such crime of violence.

10. Directory or Public Information Categories

The University, in accord with the Act, has designated categories of information about students as "directory information" which is public unless a student asks to have all of it withheld. These categories are

- Name
- Address (school and permanent)
- Telephone listing
- Electronic Mail Address
- Date of birth

- Major field of study (including current classification, year, credit load and number of academic credits earned toward degree)
- Dates of attendance (matriculation and withdrawal dates)

- Degrees and awards received (type of degree and date granted)

- Most recent previous educational agency or institution attended.

Participation in officially recognized activities and sports, and weight and height of members of athletic teams. A student wishing to keep confidential the "directory information" listed above must file a written request with the Office of the Registrar. This request may be submitted in person, by mail or fax. Once a confidential privacy flag has been placed on a student's record the directory/public information will not be released to individuals, companies or third party entities outside The University of New Mexico. The confidential privacy flag will not automatically be removed upon graduation from The University of New Mexico. If you have requested a confidential privacy flag, your name will not appear in The University of New Mexico Commencement Program.

The removal of the confidential privacy flag may be requested in person and in writing by fax or mail. The address is Records & Registration, MSC 06 3650, 1 University of New Mexico, Albuquerque, NM 87131-0001. The fax number is (505) 277-6809. The following information is needed to process the request by fax or mail: student name, social security number and signature.

11. Requests for Disclosure

University offices will maintain a record of disclosures and requests for disclosure of personally identifiable information from a student's record except when the request for disclosure is directory information, pursuant to the student's consent, or is to a school official described in this policy. It is the policy of the University to permit the student to inspect this record of disclosures and requests for disclosure pertaining to his or her records. All disclosures (except for disclosures to the student or disclosures of directory information) shall be made on the condition that the information shall not be further disclosed without the student's consent.

12. Right to Challenge Information in Student Records

It is the policy of the University that a student may challenge any information in his or her education records which he or she believes to be inaccurate, misleading or in violation of privacy. This right does not extend to reviewing grades unless the grade assigned by a professor was inaccurately recorded in the records. A student may also insert a statement in the records explaining any such material from his or her point of view. If a student wishes to challenge information in the file, he or she must make a written request for a hearing to the dean, director, or chairperson of the office which maintains the record. In most cases, the decision of the dean, director or chairperson will be final. However, a student may appeal in writing to the Associate Provost or the Vice President for Health Sciences or their designee, as the case may be, who will review the decision only if a significant question of policy or compliance with the law appears to be raised by the case.

13. Waiver of Rights Not Required

It is the policy of the University that students not be required to waive their rights under the Act before receiving University services or benefits.

14. Assistance with Problems or Questions about Compliance

If a student has questions about the provisions of the Act, he or she may contact the Office of the Registrar. If a student believes that the University has not complied with the Act, he or she should direct comments concerning this to the Office of the Registrar. If a student believes that the University has not complied with the Act, written complaints may be filed with the Family Educational Rights and Privacy Act Office (FERPA), U.S. Department of Education, 400 Maryland Avenue, SW., Washington, D.C. 20202-4605, telephone (202) 732-1807. The Registrar shall either resolve the issue, or shall refer it to the appropriate University body for resolution. Copies of and information about the Rights and Privacy Act are available in the Records and Registration Office, Student Services Office.

Change of Name

Students who need to process a change of name for their academic records must bring appropriate documentation to the Student Services Office. The appropriate documentation includes proper photo identification (valid driver's license, passport or other state issue identification) and the social security card showing the new name. No other type of documentation will be accepted.

Change of Address/Phone

Current students who need to process a change of address or phone number for their academic records may do so using LoboWeb, Personal Information-Demographic Self-Service.

Transcripts

The Records and Registration Office of UNM-LA issues unofficial and advisement copies of The University of New Mexico student records. A student may request a transcript of their academic record in the lower level of Building 2, by mail or by FAX. The address is Registrar, UNM-Los Alamos Student Services, 4000 University Drive, Los Alamos, NM 87544. The FAX number is (505) 661-4698. The following information is needed in order to process a request by mail or FAX: student name (all names used while at the University of New Mexico), social security number, date of birth and dates of attendance. The student's signature is required to authorize the release of any transcript. Proper photo identification (driver's license, Lobo Card, passport or other state issue identification) is required to obtain a transcript in person.

Transcript information and request forms are available online at <http://registrar.unm.edu>. Transcripts from other institutions that are sent to the University of New Mexico for purposes of admission are not copied or returned to the student.

Transcript Holds

Transcripts may be held for financial and nonfinancial reasons. No official transcripts will be released until the student's outstanding obligations to the University have been paid or until satisfactory arrangements have been made.

Grade Notification

Semester grades are available on LOBOWeb. If a hard copy is required, it can be obtained from Student Services, Building 2.

Residency

Summary of Regulations for New Mexico Residency for Tuition Purposes

A student who enters and remains in this state principally to obtain an education is presumed to continue to reside outside this state and such presumption continues in effect until rebutted by clear and convincing evidence of bona fide residence. A student determined to be financially dependent on an out-of-state parent or guardian also assumes the residency of that parent or guardian. The "burden of proof" is on the student. The student must secure and file the petition with the appropriate documents of evidence in the manner described herein. All documents submitted for this purpose will be kept confidential. Residency petitions will be accepted until the second Friday of each Fall and Spring semester in the Office of the Registrar in the Student Services office located in the lower level of Building 2.

To become a legal resident of New Mexico, four basic requirements must be completed by the student. Each person must meet the requirements individually.

The 12 Month Consecutive Presence Requirement

A student must physically reside in the state for 12 consecutive months immediately preceding the term for which the student submits a petition.

The Financial Independence Requirement

A student cannot be approved for residency who is financially dependent upon his or her parents or legal guardian who are non-residents of New Mexico. At the time the student applies for residency (if under 23 years of age), a copy of his or her parents' or guardians' 1040 or 1040A U.S. income tax form for the previous year must be submitted with the application. If the student is shown to be a dependent on this tax form, he or she will not be eligible to establish residency apart from his or her parents or guardian.

The Written Declaration of Intent Requirement

The student must sign a written declaration of intent to relinquish residency in another

state and to establish it in New Mexico.

The Overt Acts Requirement

New Mexico requires the completion of several “overt” acts which support the student’s declaration of intent to become a permanent resident. The required overt acts are evidence of any two of the following:

1. If the applicant is financially dependent, a copy of the parents’ or guardians’ previous year income tax form showing the applicant as a dependent and the parents’ address as New Mexico;
2. A New Mexico high school transcript issued in the past year confirming attendance at a New Mexico public or private high school within the past 12 months;
3. A transcript from an online high school showing a New Mexico address confirming attendance within the past 12 months;
4. A New Mexico driver’s license or ID card with an original date of issue or a renewal date issued prior to the first day of the semester.
5. Proof of payment of New Mexico state income tax for the previous year;
6. Evidence of employment within the state of New Mexico;
7. New Mexico vehicle registration;
8. Voter registration in New Mexico;
9. Proof of residential property ownership in New Mexico;
10. Utility bills showing the applicant name and a New Mexico address;
11. Other evidence which would reasonably support the individual’s intent to establish and maintain New Mexico residency.

Any act considered inconsistent with being a New Mexico resident will cause the request for resident classification to be denied. As such, other relevant factors may be considered in addition to the items listed above.

NOTES:

1. Any act considered inconsistent with being a new Mexico resident—such as voting, securing and/ or maintaining a driver’s license and automobile registration in another state, etc.—will cause the petition to be denied.

2. The spouse and dependent children of a person who has moved to New Mexico and has obtained permanent full time employment (sufficient documentation is required) shall not be required to complete the 12-month durational requirement. However, all other requirements must be satisfied.
3. Active duty military members stationed in New Mexico, their spouses and dependents are eligible for waivers of non-resident tuition. Members of the National Guard, their spouses and dependents are also eligible for waivers of non-resident tuition. A form must be submitted to Student Services by the second Friday of the term to obtain these waivers.

According to the University of New Mexico’s tuition policy:

Students enrolling for 6 hours or fewer during a regular semester will be charged resident tuition rates regardless of residency classification. Students enrolling for the summer session will be charged resident tuition rates regardless of residency classification.

A brochure explaining all requirements for establishing New Mexico residency and residency petitions are available from the Office of the Registrar, Student Services Office, lower level of Building 2. For more information, please call (505) 662-0332.

Mandatory Academic Advisement

All freshmen and new transfer students are required to receive academic advisement before registering for classes. All students in Certificate and Associate Degree programs are required to receive advisement every semester prior to registration.

Schedule of Classes

The Schedule of Classes is an official publication of the University, distributed each semester without charge. The publication includes course offerings, dates, times, places and procedures for registration and other important information. The schedule can also be accessed at www.la.unm.edu.

Registration Procedures

Details are outlined in the Schedule of Classes.

UNM-Los Alamos Identification Card

Each UNM-Los Alamos student will be issued an official UNM-Los Alamos Identification Card. The card will contain a non-transferable photograph, the student’s name, and the

student's UNM ID number. At the time of request for a UNM Los Alamos Identification Card, the student must present proof of identification to include at least one other identification card with picture. Students will be required to present the Identification Card to Student Services when requesting transcripts or any other services containing personal information. Students will be required to present the card when conducting any financial transactions with the Cashier/Bursar. Students will be required to present the Identification Card to Campus Bookstore staff if they wish to charge textbooks/supplies to their student accounts. The ID card initially issued to the student will be at no cost to the student. A first replacement will cost the student \$10.00, a second replacement will cost the student \$15.00, a third or subsequent replacement will cost the student \$25.00. Identification cards will be issued between the hours of 1:00 p.m. to 4:00 p.m. Monday through Friday.

Payment of Tuition and Fees

Payment of tuition and fees is required to complete registration. For specific information regarding tuition, fees, payment and payment deadline dates, refer to the Financial Information section of the current Schedule of Classes.

Enrollment Limit

Students may not take more than 18 hours during a semester and 9 hours during the summer session, except with approval from the Director of Student Services. Students in non-degree status who have not earned at least a baccalaureate-level degree must obtain permission from their academic advisor.

Enrollment Certification

Enrollment Certifications are requested by individuals, institutions or organizations for information related to a student's past or current enrollment. Information requested normally takes the form of validation of confirmed degrees, dates of attendance or whether a student is full- or part-time.

The National Clearinghouse is now the University of New Mexico's authorized agent for providing enrollment and degree verifications. If an employer or background screening firm requests this information, please have them contact the National Student Clearinghouse at (703) 742-4200 or visit their website www.studentclearinghouse.org.

The University of New Mexico will produce a standardized enrollment certification document validating a student's status for the current semester, preregistered semester and any semester for the past four calendar years. If a student wishes to have their entire academic history certified or semesters not covered by the certification process, they must request a transcript. The University of New Mexico does not certify expected graduation date.

The guidelines listed below are used primarily to determine enrollment status for financial

aid eligibility and loan deferments. Graduate students with an assistantship must submit a copy of their contract with their verification request. Students withdrawing after the 6th week of classes will be subject to grades of WP (withdrawal passing) or WF (withdrawal failing). The grade WF is included in the total course load for purpose of enrollment verification. WP is not included in the total course load for purpose of enrollment verification. Courses taken in Audit, Extension or Correspondence status are also not included in total course load, for purposes of enrollment verification.

Course Load Guidelines

Undergraduates/Non-Degree

1. Fall/Spring Semesters
 - a. Full-time: 12 or more credit hours.
 - b. Half-time: 6–11 credit hours.
 - c. Less than half-time: 5 or fewer credit hours.
2. Summer Session
 - a. Full-time: 6 or more credit hours.
 - b. Half-time: 3–5 credit hours.
 - c. Less than half-time: 1 or 2 credit hours.

Changes in Enrollment

Once registered, students may process schedule changes through the drop/add procedures during appropriate periods. Procedures for schedule changes and deadlines are published in the Schedule of Classes.

Summer Session and Short Courses.

Deadlines for processing drops, adds, withdrawals and grade options for summer and short courses vary according to the length of the course. Consult the *Schedule of Classes* for specific dates.

For 16-week courses, the following applies:

- **Add.** Students may add courses or change sections through the second week of the semester.
- **Drop.** A student may drop a course or courses without a grade during the first six

weeks of the semester.

- **Withdrawal from a Course.** After the sixth week a student may withdraw from a course until the end of the 12th week of the semester and is subject to grades of WP or WF to be determined by the instructor at the time of the withdrawal. The WF will be calculated as a failing grade in the student's grade point average. After the 12th week, course withdrawals will only be accepted with approval from the Director of Student Services. No withdrawals will be accepted after the last day of instruction of the semester, prior to final exam week.

NOTE: Faculty are not responsible for dropping students who do not attend. It is the student's responsibility to check the accuracy of their course schedule. As a consequence, you may earn a failing in a grade in a class you stop attending but did not officially drop.

- **Change in Grading Option.** Changes in grading option (including audit, pass-fail option, letter grade or graduate credit option) in any course may be made through the fourth week of the semester. It is the student's responsibility to make certain that they are registered in any course for the proper grading option.
- **Completion of Courses.** Students are responsible for completion of all courses in which they are enrolled at the University. Changes in enrollment, drops or withdrawals must be officially processed. A student not following proper course or University withdrawal procedures may be given a failing grade and will be responsible for tuition changes associated with the course.

Withdrawal from the University

- Students can withdraw from all courses on or after the first day of classes through the last day of classes prior to final exams by using LOBOWeb and dropping all their courses. Students may contact the Director of Student Services (505) 661-4692 for advisement on withdrawing from all courses.
- Summer session and short courses follow a different deadline, please see the Schedule of Classes.
- Students who withdraw during the first six weeks of classes will not receive a grade notation on their academic record. The notation on a student's record will read "Withdrew" followed by the date.
- University withdrawals initiated after the sixth week of classes will be subject to grades of WP or WF. The WF will be calculated as a failing grade in the student's grade point average. All withdrawal grades will be assigned by the instructor upon completion of the University withdrawal process. The notation on a student's record will read "Withdrew" followed by the date, along with the course name and grade

assigned.

- Students leaving the University during a semester without withdrawing according to this regulation are subject to faculty assigned grades.
- Students are responsible for all outstanding financial obligations when withdrawing. See the "Tuition and Course Fee Refunds" section for more information.

Policy on Military Withdrawals

Under faculty regulations, students who formally withdraw from the University before the end of the 12th week of the semester due to military obligations are entitled to a grade of WP in each course in which they are enrolled. Military orders or evidence of enlistment must be made available to the Dean of Students Office. A student who withdraws due to military obligations after completing 12 weeks of instruction will receive full credit for each course in which they are enrolled provided the instructor certifies a grade of C or better for the course at the date of formal withdrawal. They will receive a grade of WP if the instructor certifies a grade of less than C. Students must opt for either a tuition refund or for a grade assignment after the 12th week. A final semester senior who has satisfactorily completed at least half of the work in courses for which they are enrolled that semester, provided these would complete their degree requirements, may be certified for graduation by the faculty of their college.

General Academic Regulations

Students are responsible for complying with all regulations of the University, their respective colleges and the departments from which they take courses, as well as for fulfilling all degree requirements. Students are responsible for knowing and complying with all academic regulations.

Change of College

Undergraduate students who desire to gain admission to a degree-granting unit or to change their enrollment from one degree program to another within the University must petition the Associate Director of Student Services. A change in degree program after the third week of the semester will not be effective until the following semester. At the time of graduation, students must be enrolled in the UNM-Los Alamos degree program from which they receive their degree.

Class Hours and Credit Hours

A class hour consists of 50 minutes. One class hour per week of recitation or lecture

throughout a semester earns a maximum of 1 credit hour.

Course Numbering System

Courses offered at the University of New Mexico are numbered from 001 through 799:

- 001 to 100 courses may or may not carry credit, but they are not applicable toward a baccalaureate degree.
- 101 to 199 courses, lower division, normally are open to freshmen.
- 200 to 299 courses, lower division, normally are open to sophomores.
- 300 to 499 courses, upper division, normally are open to juniors and seniors, fifth year undergraduates and graduates
- 500 to 799, graduate and professional, normally are open only to students enrolled in the graduate degree programs, the School of Law or the School of Medicine.

NOTE: Undergraduate or non-degree students without a degree may not enroll in any graduate programs (courses numbered 591, 592 and 593) for undergraduate credit. Freshmen may in some instances qualify for courses numbered in the 200s. Courses numbered 300 and above are not open to lower division students (freshmen and sophomores) except in rare instances and then only with the approval of the Bachelor and Graduate Program staff. When appropriate, students may be disenrolled from courses numbered 200 and above. See the individual program sections of this catalog and the UNM catalog for specific regulations.

Grades

UNM-Los Alamos utilizes a fractionated grading system. Following are the allowable grades and associated grade points:

A+	4.33
A	4.00
A-	3.67
B+	3.33
B	3.00
B-	2.67
C+	2.33

C	2.00
C-	1.67
D+	1.33
D	1.00
D-	0.67
F	0.00

CR Credit. Gives credit for the course but is not computed in the grade point average. CR credit is the equivalent of at least a grade of C. At the graduate level CR is used to report completion of a master's thesis or doctoral dissertation. (See the following pages for specific information concerning pass/fail [CR/NC] option grading.)

NC No Credit. Not computed in the grade point average. At the graduate level NC is also used to report unsatisfactory completion of master's thesis or doctoral dissertation. Certain workshops and courses may be offered under CR and NC as defined above.

I Incomplete. The grade of I is given only when circumstances beyond the student's control have prevented completion of the work of a course within the official dates of a session. (See the policy on Removal of Incomplete.)

AUDIT Audit is recorded for completion of enrollment in an audited course. No credit is earned for an audit grade option.

WP Withdrawal Passing. All approved course withdrawals after the sixth week of classes are subject to the grade of WP, if passing the course at the time of withdrawal.

WF Withdrawal Failing. All approved course withdrawals after the sixth week of classes are subject to the grade of WF, if failing the course at the time of withdrawal. The grade of WF will be calculated as a failing grade in the student's grade point average.

WNC Withdrawal, No Credit. Not computed in the grade point average. WNC indicates officially withdrew with unsatisfactory (C- or below) performance in pass/fail (CR/NC) option enrollment or course approved for pass/fail (CR/NC).

W Withdrawal. A W grade is used for approved administrative withdrawals only at the end of a semester. Examples of administrative withdrawals include: determination by the instructor that the student never attended the class, processing errors, catastrophic illness of the student or other reasons beyond the student's control.

Grade Point Average

An undergraduate student's grade point average is calculated by dividing the total number of grade points earned at The University of New Mexico by the total number of hours attempted. These hours must be attempted in courses with letter grades and the courses must be numbered 100 or above. Courses for undergraduate students given a grade of W, WP, WNC, CR, NC, PR or I are excluded in the grade point average calculation. For graduate students, the Office of Graduate Studies, internally for their record keeping processes, calculates a grade of "I" as a 2.0 until replaced by another letter grade.

Beginning Fall 2006 the academic transcript reflects a level GPA. The courses a student takes becomes a part of the level to which the student has been admitted. If a student is in an associate degree program the level will be associate degree, and all the courses taken in that level are reflected in the associate GPA. Courses that are not remedial or technical are also calculated into the undergraduate GPA. If the student is in a bachelor's degree program, the courses taken in that status are calculated in the undergraduate GPA. The various levels are Associate, Undergraduate, Non-Degree Undergraduate and Non-Degree Graduate. Each level has a GPA.

The academic standing of all students is reviewed at the end of each semester and Summer session. At such times, all students who are deficient in scholarship are placed on probation, or suspended, in accordance with the regulations of their college.

NOTE: This is a general University of New Mexico grade point calculation. Schools and colleges within the University may compute the grade point average differently.

Grades earned in courses taken at other institutions are not included in calculation of The University of New Mexico- Los Alamos grade point average. The grade point average will reflect only courses taken at The University of New Mexico-Los Alamos.

Grade Options

Pass/Fail (CR/NC) Option

1. This grading option is open to students enrolling in courses that do not apply to their major.
2. A student is permitted to enroll in a maximum of 4 credit hours per semester under the pass/fail (CR/NC) grading option.
3. CR (credit) is the equivalent of at least a grade of C. Students who do not satisfactorily complete a course under pass/fail (CR/NC) grading will receive NC (no credit).

4. A course may be changed to the pass/fail (CR/NC) grade option. See current *Schedule of Classes* for deadlines.
5. A maximum of 24 credit hours graded pass/fail (CR/NC) will be allowed toward a baccalaureate degree. Graduate students may not count more than 6 hours of course work in which a C (2.0), C+ (2.33) or CR was earned.
6. Courses that are specifically approved for pass/fail (CR/ NC) are not included in the 24-hour maximum allowed toward degree requirements.
7. The following may not be taken under the pass/fail (CR/ NC) option:
 - a. Courses in the University Honors Program and the Undergraduate Seminar Program.
 - b. Courses that are part of the student's major (as defined by the major department) with the exception of those courses especially approved for use of pass/ fail (CR/NC) grading.
 - c. Courses that are part of the student's minor (see specific college and departmental requirements).
 - d. Correspondence courses.
 - e. Courses the student is repeating after first having taken the course under the regular grading system.

Some schools, scholarship committees and honorary societies do not accept this grading system and convert grades of "Credit" to C and "No Credit" to F when computing grade point averages or may otherwise penalize students who use this option.

NOTE: Students may not be penalized by a department if, when selecting or changing a major field, they have taken a course in their major on a pass/fail (CR/NC) option basis.

Audit

A student may register in a course for audit, provided written permission of the instructor is obtained. (See current *Schedule of Classes* for deadlines.) A student who fails to attend class may be dropped at the instructor's request. **The fee for audited courses is the same as for credit courses.**

Audit enrollment receives no credit and is not included in the student's total course load for purposes of enrollment certification. Audited courses appear on the academic record. Courses taken for Audit may be repeated for credit.

Repetition of a Course

A student may repeat any course but will receive credit only once unless otherwise noted in this catalog. **ALL ATTEMPTS** and **ALL GRADES** are computed in the student's grade point average. A grade replacement policy is available for repeated course work as described below.

Grade Replacement Policy

The course repeat policy was revised by the Faculty Senate to include a grade replacement option effective Spring semester 1991. Under this policy, only undergraduate students may repeat a course for a higher grade and have the lower grade removed from the grade point average. This revision is an option for students who meet the criteria outlined below. Repeated courses for students who do not meet the criteria or who choose not to make use of the option automatically fall under the existing policy as described under “Repetition of a Course.”

The following outlines the procedure for the implementation of this course repeat (grade replacement) option. **NO EXCEPTIONS WILL BE MADE TO THIS POLICY.**

1. The Grade Replacement option policy is effective as of Spring semester 1991 and only affects UNM course work from Spring 1991 forward. This means that the first attempt in a course cannot have been prior to Spring Semester 1991. The policy is not retroactive to any semester prior to Spring 1991.
* A student who fails a course at The University of New Mexico and repeats the same course with a grade of C or better at another college or university may have the credit accepted for transfer, but the grade received at The University of New Mexico will continue to be computed in the grade point average.
2. Students who are in undergraduate status are eligible to use this policy and only course work being applied toward an undergraduate degree will be considered for a grade replacement.
3. A repeated course must result in an improved grade in order to replace the other grade (e.g., a D cannot replace a D). The higher grade will remove the lower grade from the grade point average and earned credit hours. Grades of CR, NC, PR, WP and W are not replaceable grades since they do not affect the grade point average.
4. The process is not automatic. Students must initiate the process by completing a form in the Student Services Office, indicating which course is to be replaced. The course numbers and titles must be identical, except where equivalencies or a change has been noted in The University of New Mexico-Los Alamos Catalog. No substitute courses are acceptable. Forms will be Student Services Information accepted after the second attempt in the course has been completed.
5. A grade replacement may be applied to only 12 hours of repeated course work. Only one grade replacement is allowed for each course, regardless of the number of times the course has been repeated.
6. Once a grade replacement has been approved, the process cannot be reversed or changed.

7. No grade may be replaced after a degree has been awarded.
8. All grades will remain on the record. An “N” will appear on the transcript next to the course that has been replaced.
NOTE: This policy applies only to courses taken and repeated at The University of New Mexico or one of its branches.

Incomplete (I) Grade

According to academic policy, incomplete grades must be completed before a student is eligible to graduate from the University of New Mexico-Los Alamos.

The grade of “I” is given only when circumstances beyond the student’s control have prevented completion of the coursework within the official dates of a semester/session.

Students should not re-enroll or re-register (for credit) in a course in which an incomplete has been received in order to resolve the “I” (incomplete) grade. If an instructor requires the student to repeat the class in order to resolve the Incomplete, the student must register for the course on an audit basis.

Incomplete grades must be resolved no later than one year (twelve months) from the published end day of the semester in which the grade was assigned. Incomplete grades not resolved within the time frame stated in this policy will be converted automatically to an F (failure) grade.

Students resolving Incompletes in their semester of graduation must have the process completed (including the reporting of the grade to the Student Services, Building 2) by the deadline. Students are responsible for informing instructors that they are graduating and the grade(s) must be reported by the appropriate deadline. Failure to complete the process as described could result in the postponement of graduation until the following semester.

The instructor of record will report the final grade for the course in which the Incomplete was assigned to Student Services.

Extension of Incomplete

A student may apply for an extension of the time allowed to complete the required course work removing the “I” grade. The request for extension may be obtained in the Office of Records and Registration. For the student who re-enrolls in residence, a one-semester extension may be granted. If an extension is granted, it is the student’s responsibility to

remove the “I” grade by the date indicated.

Change of Grade

The instructor of a course has the responsibility for any grade reported. Once a grade has been reported to the Student Services Office, it may be changed by submitting a grade change form to the Student Services Office. Only the instructor who issued the original grade (instructor of record) may submit any change. The change of grade must also be approved by the college dean or departmental chairperson **if submitted 30 days after end of semester. Any change in grade must be reported within 12 months after the original grade was issued and prior to graduation.** Grade changes may be referred to the Student Services Office for approval.

Grade Petition Procedure

1. A student seeking retroactive withdrawal, enrollment or disenrollment; extension of time for removal of an incomplete grade or a grade option change; or further academic record changes involving exceptions to the rules governing registration and academic records, may submit petitions to the Student Services Office. **This petition process does not cover disputes involving academic judgment (Refer to the UNM Pathfinder, “Student Grievance Procedure,” Article 2, Academic Disputes).**
2. The petition must state the nature of the request, specify the semester involved, the course and section number, the student’s name, identification number, mailing address and telephone number. The petition must also state the reason for granting the request and include documentation of extenuating circumstances, such as medical, family or employment needs. The petition must be typed and signed.
3. Students may only petition grades up to one year after an instructor and dean grade change form can be utilized to change a grade. (Effective as of April 2005 as approved by Faculty Senate Operations Committee.) This means no grade change can be petitioned after two years in which the course(s) was/were taken.
4. Upon receipt of student’s petition, the instructor(s) involved will be contacted for a statement concerning the request.
5. The petition (along with instructor comments) will be forwarded to the Grade Petition Committee for review and a decision. If the petition is approved, appropriate student is responsible for tuition incurred.

6. Students will be notified in writing of the outcome of the petition. The decision of the subcommittee is final.
7. The student is responsible for tuition and fees incurred.

Academic Renewal Policy

Academic Renewal applies to students seeking undergraduate degrees who have been readmitted to UNM-Los Alamos after an absence of **five years** or more. The procedure allows a currently enrolled student to request their academic record be reviewed for the purpose of evaluating previously earned UNM-Los Alamos credits and recalculating the student’s grade point average from the point of readmission.

The student may obtain a petition from the Student Services Office, lower level of Building 2. If all criteria are satisfied, the petition will be approved and the academic record appropriately noted.

Academic Renewal Guidelines

NOTE: Non-degree, second undergraduate degree or graduate students are not eligible for Academic Renewal.

1. Academic Renewal may be applied only once and is not reversible.
2. An absence of five or more years must have elapsed between readmission and the last enrollment at UNM-Los Alamos.
3. The student must be currently enrolled in an undergraduate degree program. Additionally, college entrance requirements such as minimum hours and grade point average must still be met after Academic Renewal has been applied.
4. After readmission to UNM-Los Alamos, at least 12 credit hours, but no more than 36 credit hours, must be completed in good standing (2.00 GPA or better) before Academic Renewal can be applied.
NOTE: If the degree-granting unit has placed the student on probationary status, it is not automatically changed by Academic Renewal.
5. All graduation requirements must be satisfied after Academic Renewal, i.e., minimum earned credit, residence credit requirement, cumulative grade point average, etc.
NOTE: Credit earned prior to Academic Renewal will not count toward satisfying the residence credit requirements.

6. All courses taken prior to Academic Renewal will remain unaltered on the record. An appropriate notation will be added to the record to indicate Academic Renewal. Courses with a grade of C or CR or better taken prior to Academic Renewal will be carried forward as earned credits. Acceptability of these credits towards a degree will be determined by the degree-granting unit.
7. Courses with a grade of C- or below taken prior to Academic Renewal will be noted and will not count for earned credits or for satisfying any graduation requirements.
8. Academic Renewal, when applied, will be effective as of the date of the readmission following the five-year absence.
9. The cumulative grade point average after academic renewal will be calculated on the basis of courses taken since the readmission following the five-year absence.

Classroom Conduct

The instructor is responsible for classroom conduct, behavior and discipline. Any action that would disrupt or obstruct an academic activity is prohibited. The instructor may refer situations involving classroom misconduct to the Dean of Instruction or Director for Student Services for additional action under the "Student Code of Conduct" as published in the *UNM-LA Student Handbook*.

Use of classrooms or other facilities during scheduled activities is limited to enrolled students and University personnel. Use of these facilities during nonscheduled periods should be arranged with the appropriate department or other division of the University.

Smoking, eating and drinking are prohibited in all classrooms and teaching laboratories, including seminars.

Dishonesty in Academic Matters

Each student is expected to maintain the highest standards of honesty and integrity in academic and professional matters. The University reserves the right to take disciplinary action, including dismissal, against any student who is found responsible for academic dishonesty. Any student who has been judged to have engaged in academic dishonesty in course work may receive a reduced or failing grade for the work in question and/or for the course. Academic dishonesty includes, but is not limited to: dishonesty in quizzes, tests or assignments; claiming credit for work not done or done by others; hindering the academic work of other students; and misrepresenting academic or professional qualifications within or outside the University.

Misrepresentation

Nondisclosure or misrepresentation in filling out applications or other University records will make a student liable for disciplinary action, including possible dismissal from the University.

Scholastic Regulations

Attendance

Policies regarding student attendance at class meetings are set by each instructor. **Students should not assume that nonattendance will lead to being dropped from class. It is the student's responsibility to initiate drops or complete withdrawals utilizing LOBOWeb.**

A student with excessive absences may be dropped from a course with a grade of WF, upon recommendation of the instructor. Instructor initiated drops will be submitted to the Registrar's Office.

Dismissal

Students are subject to dismissal from a college or a degree program based on minimum requirements set by that college core program. Please refer to each college section in the *UNM Catalogue* and the program section of this catalog for specific requirements. Dismissal from a college or degree program is not the same as suspension but may preclude the student from enrolling at the University.

Probation

Probationary status serves as a warning to students that they are no longer in good academic standing and that they may be suspended.

Undergraduate students who have 30 or fewer attempted hours must have a cumulative grade point average of at least 1.70 to be in good standing. Thereafter, the cumulative grade point average to remain in good standing is at least a 2.00. Undergraduate students are placed on probation at the end of any semester (or Summer session) for which their cumulative grade point average falls below these minimum requirements. Special requirements may be placed on students who are on probation.

Degree-Granting Programs and Non-Degree Status

Students in degree-granting programs or in non-degree status may be placed on academic probation at the end of any semester if they fail to meet the minimum cumulative grade point average required to remain in good standing in their program. The minimum grade point average is at least a 2.00 but is higher in some programs. Students must familiarize themselves with the academic regulations of their program.

Suspension

Students on suspension may not enroll for classes at UNM-Los Alamos until their suspension period has been completed.

Degree-Granting Programs and Non-Degree Status

Students are eligible for suspension after a semester on probation if their cumulative grade point average remains below the minimum required to be in good standing in their college.

Suspension Period

Students suspended for the first time may not enroll for classes at the University of New Mexico-Los Alamos for a period of one semester from the date of the suspension. Students suspended for the second time may not enroll for classes for a period of two semesters from the date of the suspension. Students suspended for the third time may not enroll for classes for a period of five academic years from the date of the suspension.

NOTE:

1. Summer sessions are counted with the following fall semester for purposes of this policy, e.g., a student suspended at the end of a spring semester may not attend either the following summer session or fall semester.
2. Students absent from the University for a year or more, for suspension and/or any other reason, must reapply for admission to the University.
3. Students who are accepted for readmission after suspension will be readmitted on probation in the accepting college.
4. College deans may specify the number of hours for which a student may enroll following a suspension. They may also require students to drop hours or courses that seem beyond their abilities.
5. Attendance at another institution during suspension must be indicated on

the student's application for readmission and an official transcript must be sent to the Student Services Office as part of the reapplication.

Student Financial Aid

A college education is an investment in your future. It is an investment that will pay increasing dividends in earning power and in the quality of your life. The basic premise underlying student financial aid is that the primary responsibility for a student's education rests with his or her family. When the resources of the family are not sufficient to meet college costs, the student may be eligible to receive financial assistance. This aid may come in the form of scholarships, grants, work programs and/or student loans.

If you feel you may need financial help to pay for college expenses, you should apply for financial aid to determine your eligibility. The following information will explain the application process and answer questions about costs to attend and financial aid at UNM-Los Alamos. To maximize your opportunity for funding, your application must be received by March 1. You must also respond to any request for additional information in a timely fashion. Pell Grants and Direct Student Loans remain available to eligible students who submit applications after the March 1 priority date.

The Free Application for Federal Student Aid (FAFSA) is used to apply for all types of federal and state need-based aid. Students can apply for financial aid on the Web or by completing the paper application. We encourage students to apply on the Web. The address is: <http://www.fafsa.ed.gov> UNM-Los Alamos' Federal School Code is 002663. All prospective students must be admitted to UNM-Los Alamos to receive an offer of financial aid.

The costs of attending UNM-Los Alamos include: 1) tuition and fees; 2) room and board; 3) books and supplies; 4) transportation; 5) personal expenses; and 6) child care costs, if applicable.

To be considered for financial aid, students must apply every year.

For additional information regarding costs and financial aid at The University of New Mexico-Los Alamos, please access our web page at: www.la.unm.edu

Satisfactory Academic Progress

To retain eligibility for financial aid, students must reestablish their need for funds by submitting the FAFSA application each year, and they must meet a minimum standard of academic performance in their course work and progression toward a degree. All students

will have their academic progress monitored each semester to determine continued eligibility for assistance. There are three major components to UNM-Los Alamos' Satisfactory Academic Progress Policy:

Grade Point Average: Students are required to maintain a grade point average consistent with graduation requirements for their major as follows:

- While completing the first 30 credit hours as an undergraduate, a student must attain a minimum 1.7 GPA.
- Students with more than 30 credit hours must sustain a minimum 2.0 GPA.
- Graduate students must sustain a minimum 3.0 GPA.

Completion rate: Students must successfully complete at least 67% of the total credit hours they attempt. Classes in which grades of A, B, C, D or CR are earned will be considered completed. Repeated courses were already counted as completed, and will not be counted twice. All attempted credit hours from any college (including non-degree hours) are counted whether or not financial aid was received. This calculation includes all hours in which a student is registered at the time of withdrawal. Remedial classes and English as a Second Language (ESL) classes are also counted as attempted credit hours. Courses taken for AUDIT are not counted in the student's total course load for purposes of financial aid eligibility. For graduate students, 100- and 200-level classes count as hours attempted, but not hours earned, because they will not count toward the completion of a graduate degree.

Maximum time frame: Undergraduate students must complete their program of study within 150% of the published length of the program, measured in credit hours attempted. Example: if the published length of the academic program is 66 credits, the maximum time frame for completion is 99 attempted credits. All attempted credit hours from any college, including non-degree hours, and hours attempted in completing a prior certificate or degree will count toward the maximum allowable credits regardless of whether financial aid was received. Courses with assigned grades of F, WF, W, WP, I, NC and "repeated" courses all count as attempted credit hours. In addition, remedial classes and ESL classes are counted in this calculation, even though these classes do not count toward the student's graduation requirements. To receive financial aid, graduate students must complete their degree within the maximum time frame allowed by their graduate program.

Enrollment Requirements for Financial Aid

To receive financial aid, students must generally be enrolled at least half-time as a regular student in an eligible program. Scholarships generally require full-time enrollment. Courses taken as audit are not included toward financial aid enrollment requirements.

Award amounts are generally prorated according to enrollment status.

The student is responsible for meeting minimum enrollment requirements. Students knowingly receiving aid to which they are not entitled may be in violation of University policy and state or federal laws. If you have any questions please contact the Financial Aid Office.

Enrollment Requirements

Undergraduate Students

Full-time 12 hours

Half-time 6 hours

Non-resident Students

The student is responsible for obtaining the correct residency classification prior to the end of the second week of the semester. A student not classified as a New Mexico resident will be charged as a non-resident. Please refer to the Residency section in this catalog.

Federal Student Loans

The University of New Mexico is no longer a participant in the William D. Ford Direct Loan Program. Federal loans are now serviced by New Mexico Student Loans. Students wishing to borrow can contact the Financial Aid Office for more information.

Typical Sources of Financial Aid

Program	Per Academic Year	Amount
Federal Pell Grant	Maximum	\$ 4,731
Federal Supplemental Ed. Opportunity Grant	Maximum	\$ 1,000
State Student Incentive Grant	(Based on 2007-2008)	\$ 1,500
UNM-LA Bridge to	Tuition	Tuition
Success Scholarship	Amount	Amount
UNM Lottery	Tuition	Tuition
Scholarship	Amount	Amount
Federal /State College Work-study	Undergraduate	\$ 4,000
Federal Perkins Loan	Maximum	\$ 4,000
Federal Stafford Loan: (Subsidized)	Freshman	\$ 3,500
	Sophomore	\$ 4,500
	Junior/Senior	\$ 5,500
Federal Stafford Loan (Unsubsidized)	Freshman	\$ 9,500*
	Sophomore	\$10,500*
	Junior/Senior	\$12,500*

**Minus any subsidized amount borrowed*

PLUS Loans

(Parent Loan for Undergraduate Students) :

Cost of Education
minus financial aid awarded

Student Employment

Students seeking part-time employment while attending UNM-Los Alamos may apply for a work-study position. Visit <http://www.unm.edu/jobs/> to see what positions are available.

Payment by Financial Aid:

Financial Aid disbursement is done during the second week of class, unless otherwise specified in the financial aid section of the UNM-LA website. Registered students should use LOBOWeb to obtain information as to required payment and anticipated financial aid.

- Student charges for any services, sales or fines will be collected from the first available source of financial aid (grants, scholarships or loans) even if due date is later than aid release date.
- Students must be registered full time prior to receiving aid or have financial Aid adjust required number of hours to be eligible for aid. It is your responsibility to visit the Financial Aid Office to be certain your aid will be available, and you will not be disenrolled.

If a delay in receipt of your financial aid occurs, you may wish to complete a promissory note application and pay the first installment and any processing fees at the Cashier's Office to avoid disenrollment. College Work-Study awards will not be considered in arranging for payment.

If your tuition has been deferred based on financial aid, and you decide not to attend the University of New Mexico-Los Alamos, you must officially withdraw through <http://unm.edu/~unmreg/> prior to the 100% refund deadlines online in the Schedule of Classes at www.la.unm.edu.

Crediting Financial Assistance to a Student's Account

Students who are receiving financial assistance through programs detailed below will have their awards automatically credited to their accounts beginning on the Friday before classes if financial aid has been approved and awarded.

These programs include:

1. PELL Grant
2. Supplemental Educational Opportunity Grant (SEOG)
3. State Student Incentive Grant (SSIG)
4. Federal Perkins Loan
5. Other Grants and Scholarships
6. FFELP Loans/LINK Loans

Financial assistance awards will not be credited to a student's account until the student has registered for the required number of hours and has met all respective financial assistance source program requirements. Students will receive any remaining balance after deductions of current and past due charges through Direct Deposit by visiting <http://my.unm.edu>. If not signed up for Direct Deposit students will receive funds in a refund check sent to his or her mailing address of record, after the third week of class.

Students who are eligible for and will be receiving funds from external scholarships will not have those funds automatically credited to their accounts but must visit the Financial Aid Office to have scholarships applied to their account and/or receive any surplus funding.

After Financial Aid has processed external scholarships and sent checks to the Cashier's Office, each student must visit the Cashier's Office to endorse the check(s).

Finding Out About UNM-LA

The Student Services Office located in the lower level of Building 2, (505) 662-0332, provides general undergraduate information about the University to prospective students. This information includes degree and course offerings, admission requirements and procedures, expenses, financial aid, scholarships, registration, housing, and special services and programs.

With sufficient notice, the Student Services Office can arrange for appointments with faculty, academic advisors, admissions officers, University representatives and a tour of the residence hall and the campus.

Emergency Message Service

The Emergency Message Service is provided to reach students on campus. When an emergency arises, call (505) 662-0332. The staff will then access the student's schedule from the database file and determine if it is possible to reach the student in class. A staff member then takes a message directly to the student's classroom. The responsibility of informing family, friends, schools and day care centers of this service and its corresponding phone number rests with the student.

New Student Orientation

Orientation is designed to assist new students in making a successful transition into the University. The orientation programs include information on UNM-Los Alamos' services and policies, academic advisement, registration and strategies for coping with college. Attendance at an orientation program is required for all beginning freshmen and transfer-freshmen students. It is an ideal time to begin exploring your new environment. The program is coordinated by the Student Services Office, located in the lower level of Building 2, (505) 662-0332.

Student Attendance/Class Absences

Students are expected to attend all meetings of the classes in which they are enrolled. Absences due to illness, or to authorized University activity such as field trips, athletic trips, etc., are to be reported by the student to his/her instructor(s). If a student is unable to contact his/her instructor(s), the student should leave a message with the Office of Instruction. The reporting of absences does not relieve the student of responsibility for missed assignments, exams, etc. The student must take the initiative in arranging with his/her instructor(s) to make up missed work. It is expected that the faculty member will cooperate with the student in reasonable arrangements in this regard. Verification (such as doctor's note, hospital billing, military orders, death notices, etc.) of a student's report of absence should be provided on request. The Office of Instruction is located in Building 1, (505) 662-0331.

The UNM –Albuquerque Directory

A directory listing departments, faculty and staff members, as well as each student's local and home address, telephone number, academic classification and University of New Mexico e-mail address, is published by Computer and Information Resources and Technology (CIRT). Students can request that their listing be deleted from the directory

by completing a form at the Student Services Office in the lower level of Building 2. The directory is also published online at <http://www.unm.edu/phone.html>.

UNM –Albuquerque Pathfinder

The UNM Pathfinder is the most comprehensive handbook of student services at the University of New Mexico. It is published annually by the Student Activities Center. The UNM Pathfinder gives general information, including office locations and telephone numbers, about academic support and cultural programs, athletics and recreation, student organizations, entertainment, financial services, food, health and medical assistance, housing, the University of New Mexico policies affecting students, commuting and parking and other services and programs. The Pathfinder is available online at <http://pathfinder.unm.edu/>.

Other Publications

Other publications include the UNM-LA Schedule of classes, published two times per year, which contains class schedules and up-to-date information on a variety of topics; and Stall News, a list of events and things to know posted in campus rest rooms.

UNM-LA Website at www.la.unm.edu

The campus website contains the most update information about UNM-LA, including updated class schedules, the UNM-Los Alamos Catalog and information about campus events and other news.

Student Organizations

Student Government

The UNM-Los Alamos Student Government represents students' voices to the campus administration and faculty. We collaborate with administration to support and fund social and academic activities. We provide a venue of communications and are committed to the benefit of students. To gain leadership skills, become acquainted with administration and work with fellow students to make a better UNM-Los Alamos experience, run for Student Government positions. This is your campus, so make your voice heard!

Phi Theta Kappa

Membership in Phi Theta Kappa International Honor Society will open new doors for your academic journey. To be eligible for membership:

- You must be enrolled in a regionally accredited institution offering an associate degree program
- You must have completed at least 12 hours of coursework leading to an associate degree program (part-time students may be eligible)
- You must generally have a grade point average of 3.5
- You must enjoy full rights of citizen ship in your country

Check out the Phi Theta Kappa website for more information at: www.ptk.org/members/benefits.htm

Start a Club

Contact Student Services for forms and information about starting a student club.